

**SEI**  
INDUSTRIES

**DRAGON**<sup>®</sup>  
FIRE IGNITION PRODUCTS

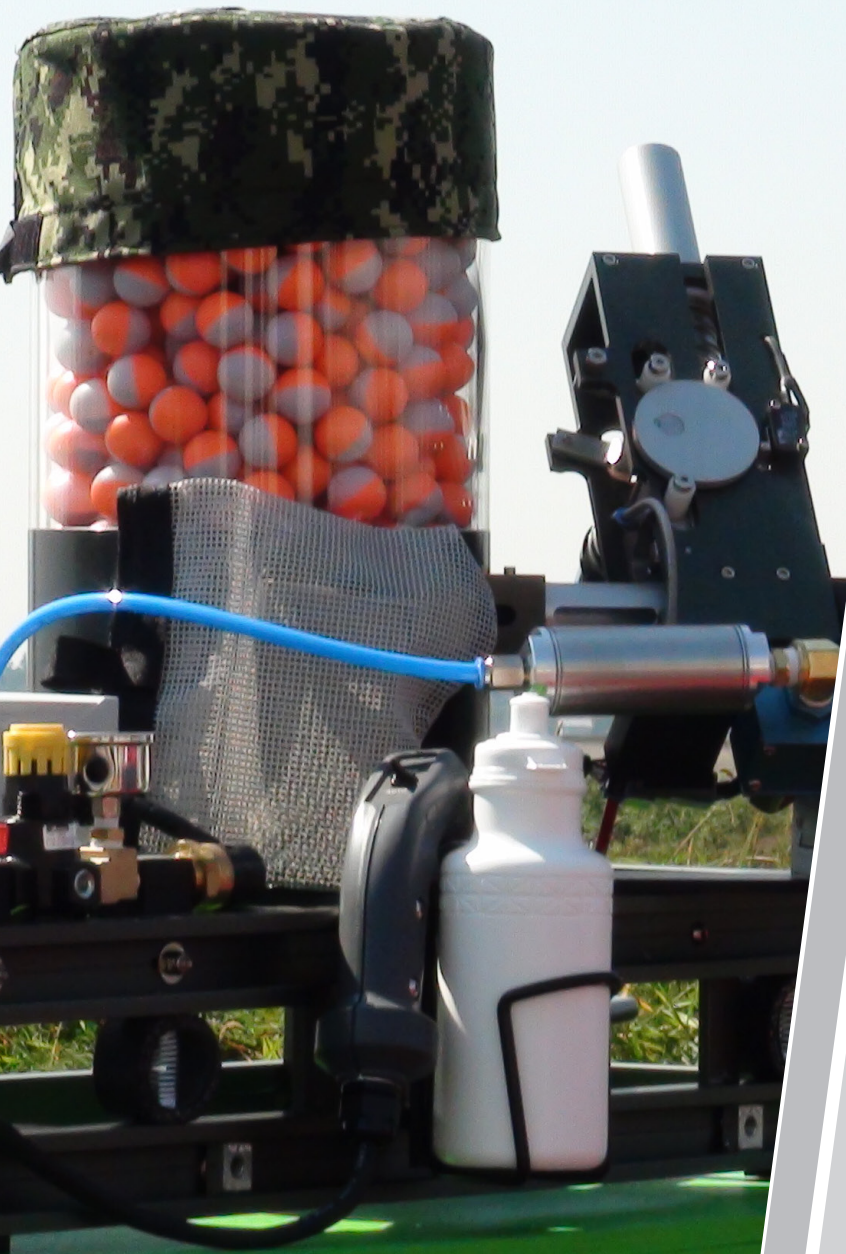

SEI Industries Ltd.  
Plastic Sphere Dispense  
Serial # 0 0 3

# ***GREEN DRAGON OPERATIONS & SERVICE MANUAL***

**2013 VERSION B**

---

**GREEN DRAGON OPERATIONS AND SERVICE MANUAL - Version B**

**Issue Date: JULY 2013**

**PLEASE READ BEFORE USING.**

**SEI INDUSTRIES LTD.**

7400 Wilson Avenue  
Delta, B.C. Canada  
V4G 1E5

Phone: (604) 946-3131

Fax: (604) 940-9566

E-Mail: [seisales@sei-ind.com](mailto:seisales@sei-ind.com)

Website: [www.sei-ind.com](http://www.sei-ind.com)

COPYRIGHT © 2013 SEI INDUSTRIES LTD. ALL RIGHTS RESERVED

PRINTED IN CANADA



---

# Table of Contents

<b>Section 1: Dragon System Overview</b>	<b>1</b>
Dragon Eggs .....	1
Green Dragon Dispenser .....	2
<i>Standard Components</i> .....	2
<i>Base Assembly</i> .....	3
<i>Hopper</i> .....	4
<i>Launcher System</i> .....	4
<i>Gas System</i> .....	6
<i>Glycol System</i> .....	7
<i>Main Control Panel</i> .....	8
<i>Remote Control</i> .....	9
<i>Power Cord</i> .....	9
Principles of Operation .....	10
<i>Loading Operation</i> .....	10
<i>Hopper Operation</i> .....	10
<i>Launcher Operation</i> .....	10
<i>Modes of Operation</i> .....	12
<b>Section 2: Installation</b>	<b>13</b>
Installation .....	13
<i>Mounting Options</i> .....	13
<i>Gas System</i> .....	14
<i>Electrical System</i> .....	15
<i>Glycol System</i> .....	16
<i>Dragon Eggs</i> .....	17
<b>Section 3: Operations</b>	<b>19</b>
Green Dragon Operations .....	19
<b>Section 4: Emergency Procedures</b>	<b>23</b>
Launcher Jams .....	23
<i>Clearing a Jam</i> .....	23
<b>Section 5: Troubleshooting</b>	<b>25</b>
Won't Power On .....	25
Won't Load .....	25
Won't Cycle .....	26
Intermittent Operation .....	27
Egg Jamming .....	27
Loss of Range .....	28
Ignition Failure .....	28

---

<b>Section 6: Service</b>	<b>31</b>
Cleaning and Storage .....	31
<i>Daily Cleaning Routine</i> .....	31
<i>Weekly Cleaning Routine</i> .....	32
Storage .....	35
System Components and Parts Lists .....	36
<i>Base Drawing</i> .....	36
<i>Base Parts List</i> .....	37
<i>Launcher Drawings and Parts Lists</i> .....	38
<i>Hopper Drawings and Parts Lists</i> .....	43
<i>Gas Manifold Drawing and Parts List</i> .....	46
<i>Control Panel Drawing and Parts List</i> .....	47
<i>Simplified Electrical Schematic</i> .....	48
<i>Simplified Pneumatic Schematic</i> .....	49
Parts Cross Reference List .....	50
 <b>Section 7: Specifications</b>	 <b>52</b>
Dispenser Specifications .....	52
Dragon Egg Specifications .....	52
<i>Safety</i> .....	53
<i>Dragon Egg Shipping Box Certifications</i> .....	53
 <b>Appendix: MSDS Sheets</b>	
Potassium Permanganate	

---

## Section 1: Dragon System Overview

The use of controlled, prescribed or back burning techniques provide an effective tool in the ongoing commitment to forest and wildland management. Delayed chemical ignition devices (DCIDs) have a lengthy, proven track record of providing a means of initiating these burns in an efficient, safe and controllable manner.

This manual details the operation and field maintenance of the Green Dragon from SEI Industries Ltd.

### Dragon Eggs

Dragon Eggs are small, 26 mm diameter, two colour (orange/white), ignition eggs made of high impact polystyrene (HIPS) plastic filled with three grams of potassium permanganate.

In this state, the eggs are stable provided the shells remain undamaged. When injected with ethylene glycol (anti-freeze), an exothermic reaction initiates.

After a delay of approximately 30 seconds, combustion commences with white smoke being expelled from the needle hole followed by sphere ignition.

Once ignited, the plastic shell is consumed as fuel. The total combustion time, following ignition, is about 80 seconds.

The Green Dragon injects a constant volume of glycol into each Dragon Egg regardless of the launch rate set by the operator. As such, the auto-ignite delay time is influenced primarily by the temperatures of the Dragon Eggs and glycol.

The indicated delay times are based on air/sphere temperatures of 50 –70 degrees F (10 – 20 degrees C). Increased temperatures will decrease the delay time. By diluting the glycol with water to a 50/50 mix, the delay time can be increased.



## Green Dragon Dispenser

### Standard Components

The primary function of the Green Dragon is to inject a measured amount of ethylene glycol into Dragon Eggs, thereby initiating an exothermic reaction, and then propel the primed eggs from the launcher.

The Green Dragon consists of eight major components.

COMPONENT	DESCRIPTION
Base Assembly	Attaches the dispenser to the operator's platform.
Hopper	Stores the unprimed eggs. Provides an egg to the launcher when required.
Launcher	Injects egg. Projects the charged egg away from the dispenser.
Gas System	Provides controlled amount of gas to expel eggs.
Glycol System	Stores the glycol. Provides a fixed quantity of glycol to the injection needle.
Main Control Panel	Provides warning indications. Loads outlet tube with eggs. Controls the launching speed. Arms the trigger switch.
Remote Control	Initiates the launching sequence. Changes the operational mode.
Power Cord	Connects the controller to a 12VDC power source.

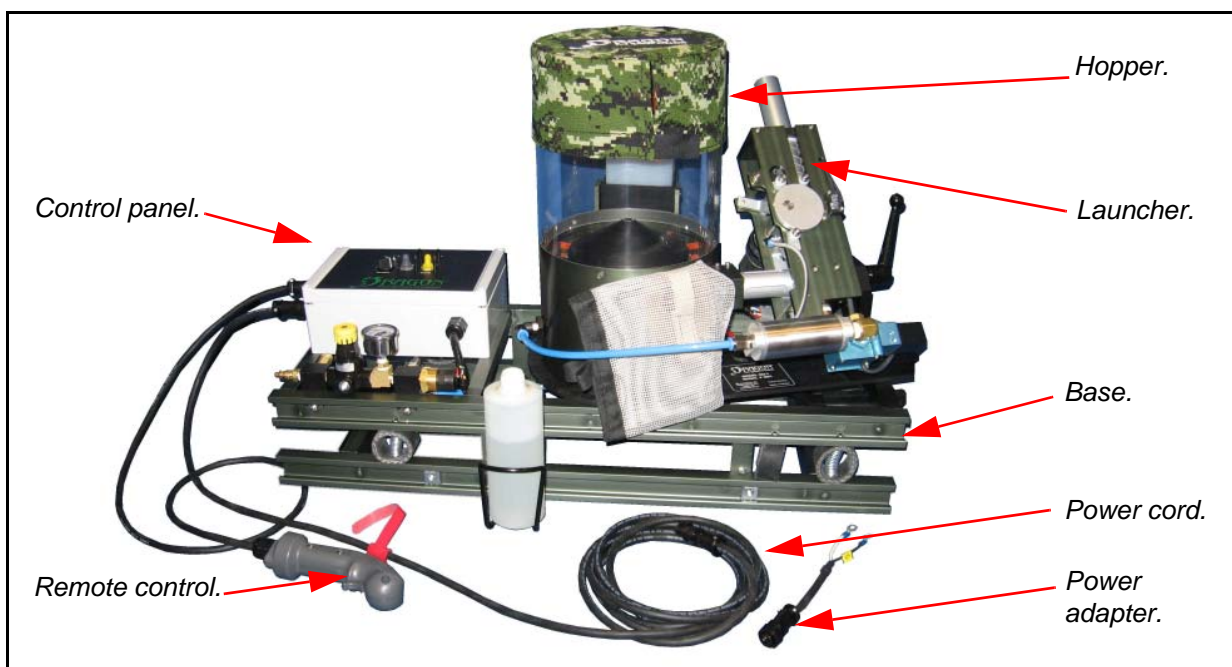

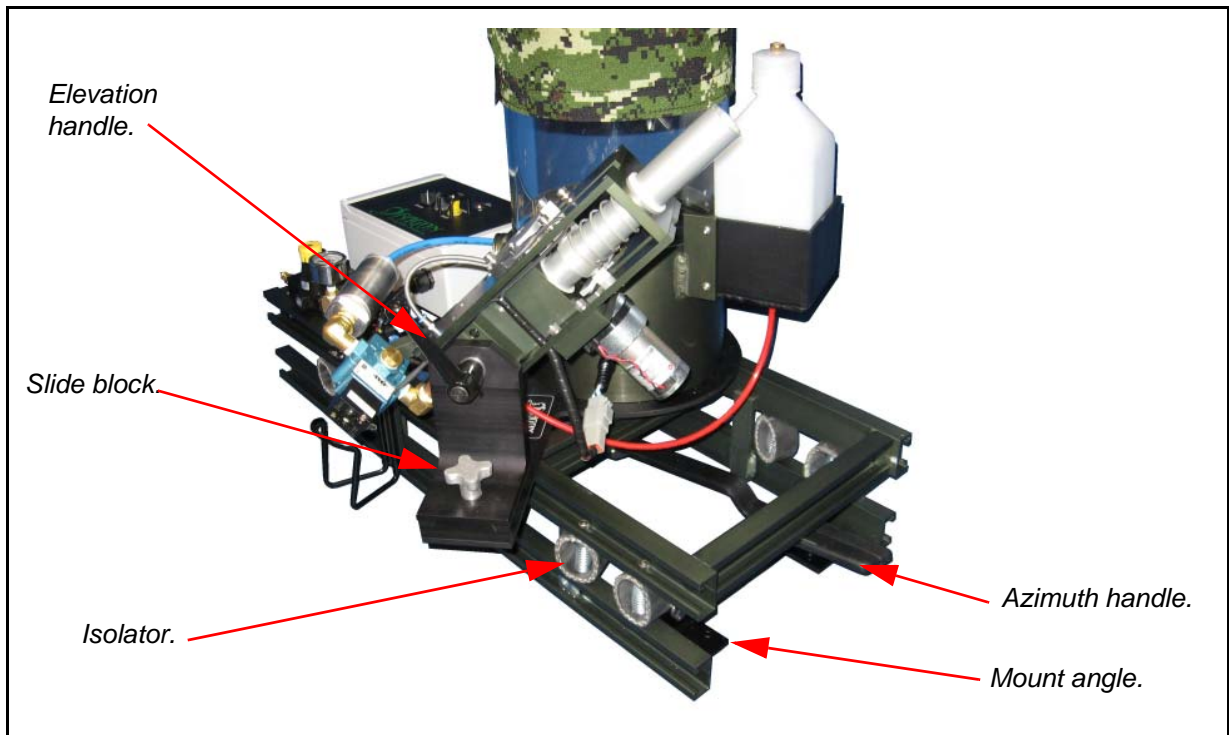
**Base Assembly**

- Mounting angles attach to either the side or end channels of the lower frame. These angles can be adjusted to any position within the channel.
- U-bolts are used to attach the mounting angles to tubular mount racks of ATV / UTV vehicles.
- The U-bolts can be removed and the angles attached directly to the shipping crate or other vehicle structures.
- Vibration isolators connect the lower frame to the upper frame.
- The azimuth lock handle controls the angle of the baseplate, hopper and launcher which rotate through 180° of adjustment.
- The elevation lock handle controls elevation of the launcher.
- The slide block allows separation of the launcher from the hopper to facilitate cleaning.

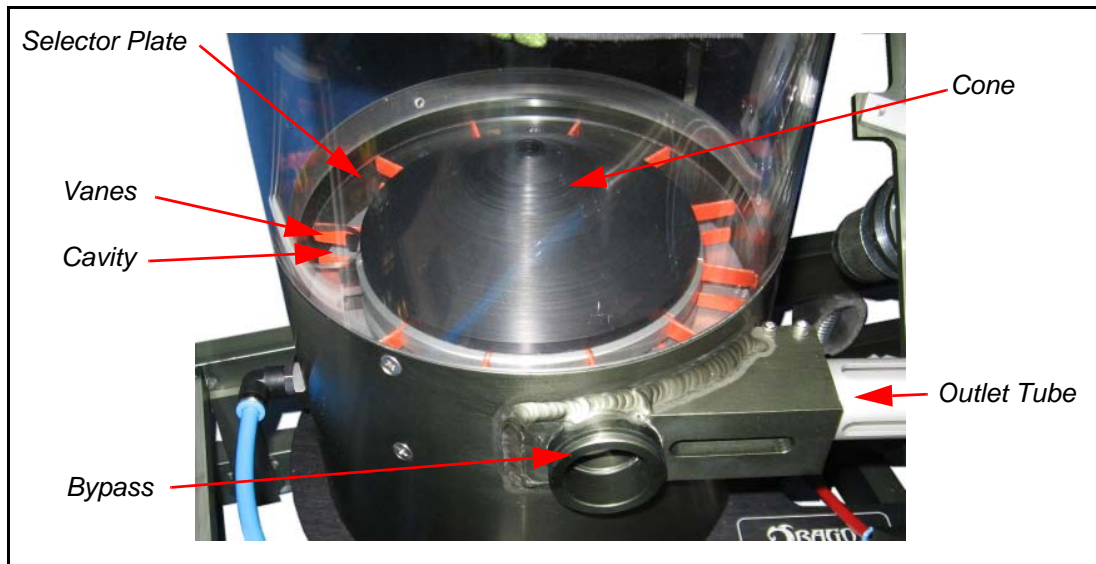
**Hopper**

- Stores 450 unprimed eggs.
- The central cone forces the eggs to move towards the outer edge of the hopper.
- On each cycle, the selector plate picks up one egg from the hopper and allows it to drop into the cavity formed by the rotor, fixed vanes, and the hopper base.
- The extractor finger strips the egg in the rotor cavity and forces it into the outlet tube.
- The outlet tube connects the hopper to the launcher.
- The flexible vanes push on the queue of eggs in the hopper outlet tube that are waiting to be injected.
- The bypass port allows eggs to be rejected from the hopper if the outlet queue is full or the dispenser is jammed.

**Launcher System**

- The receiver block of the launcher is mounted between the upper and lower frame plates.
- The upper end of the receiver is bored out to receive the reciprocating barrel.
- The lower end of the receiver is closed by the breech plug.
- There is a side port in the receiver to receive eggs from the hopper.



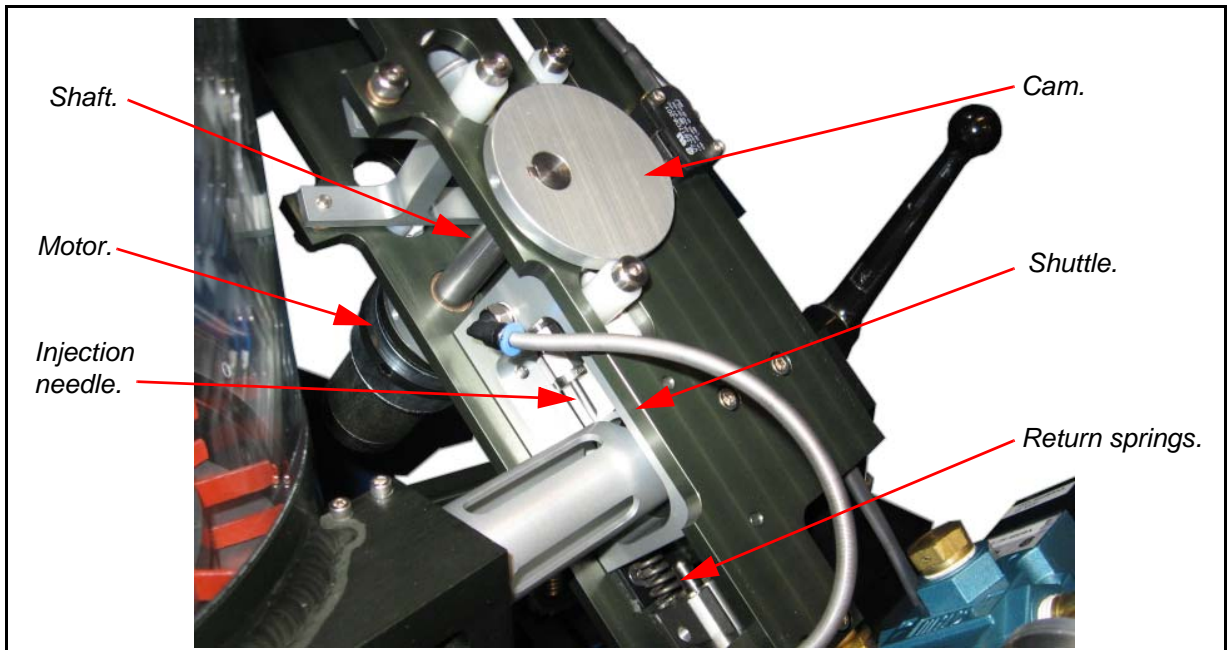

**Launcher System (continued)**

- The drive motor, shaft and drive cams control the motion of the injection shuttle and barrel.
- The injection needle shuttle reciprocates to inject and retract the needle from the egg.
- The return springs work in opposition to the cams to return the injection shuttle to its upper position.
- The barrel actuator is driven by the cams and causes the barrel to extend.
- The barrel spring works in opposition to the barrel actuator to cause the barrel to retract.
- The limit switch is activated by the upper cam and sends a signal to the controller when the launch cycle is complete.

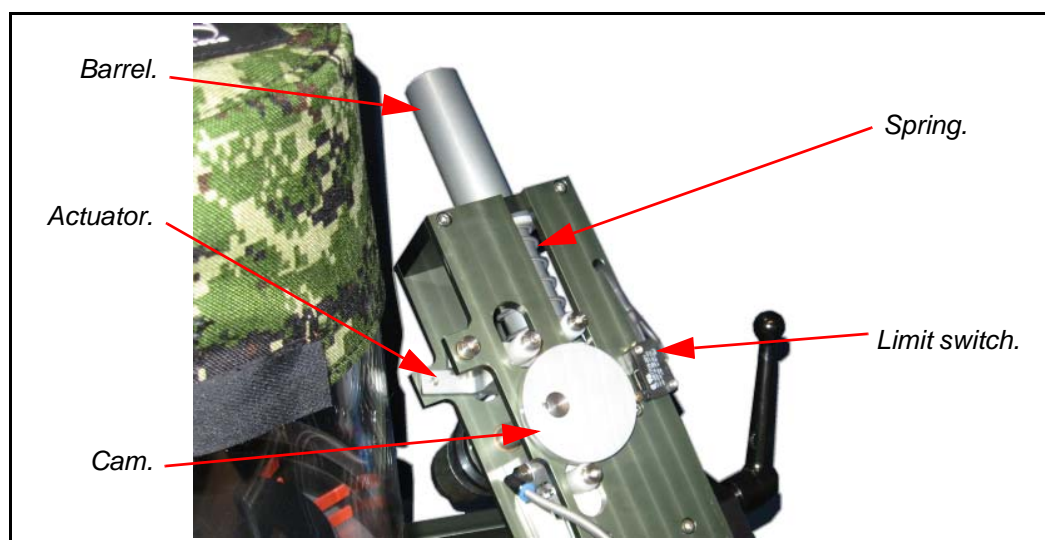

## Gas System

The Green Dragon will operate with a variety of non-flammable propellant gasses including, but not limited to, CO<sub>2</sub> and compressed air.

### CAUTION

The propellant gas must be supplied at a pressure of 150 psi or less. The Green Dragon dispenser is supplied with a 150 psi regulator designed to attach to CO<sub>2</sub> bottles with CGA-320 fittings.

- The primary regulator is connected to the gas system using flexible hose and standard industrial quick connects.
- The safety valve protects the gas system from over pressure.
- The adjustable gas pressure regulator allows the operator to control the range of the projectile. Pushing down the outer ring locks the regulator setting.
- The pressure gauge displays the regulated gas pressure.
- The low-pressure switch measures the regulated gas pressure.

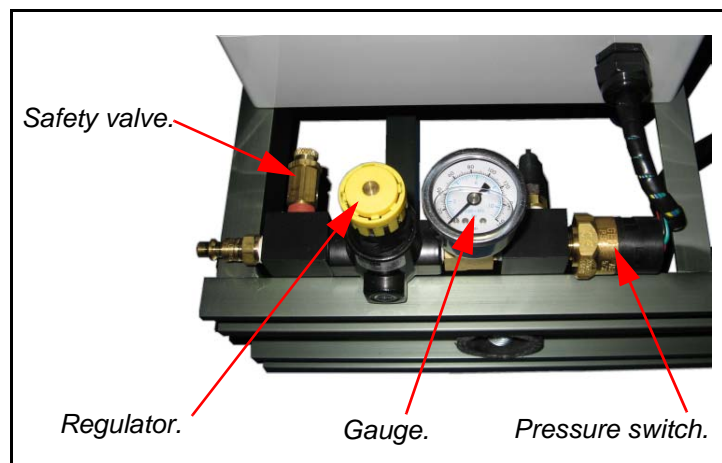
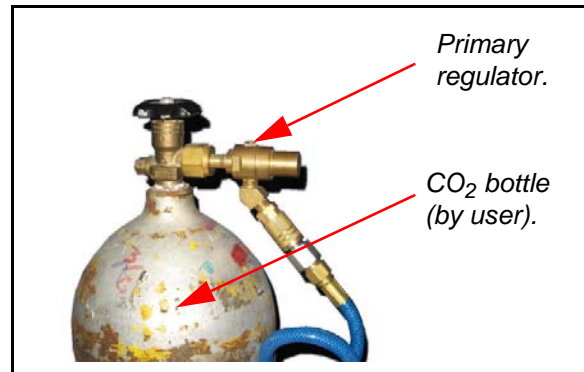

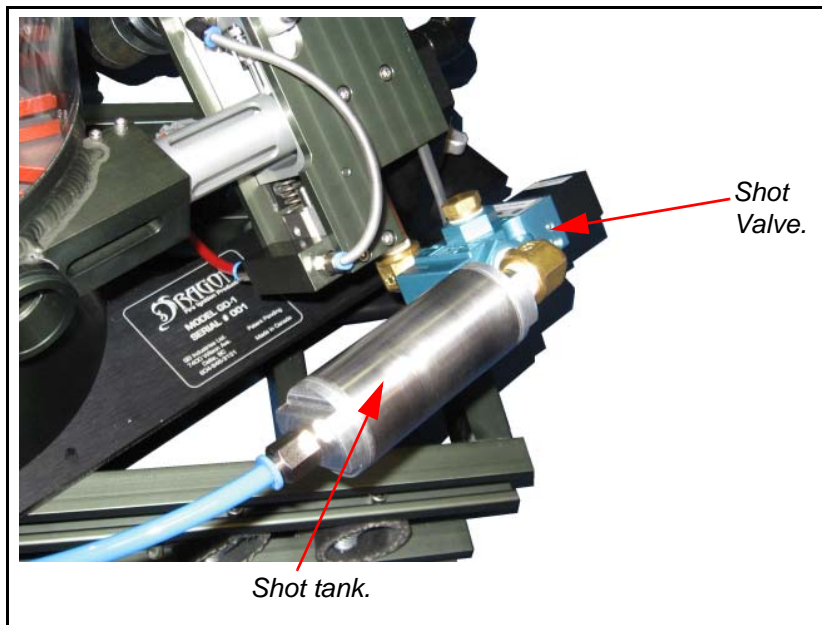
**Gas System (continued)**

- The shot tank stores the gas charge to be used each time the launcher is cycled.
- The shot tank is connected to the breech of the launcher by a solenoid control valve. Operation of the valve is controlled at the main control panel.

**Glycol System**

- The glycol bottle stores the glycol.
- A self-closing disconnect fitting is located on the bottom of the bottle. This allows the glycol supply tube to be removed from the bottle and the bottle to be removed from the dispenser for easier filling and draining.

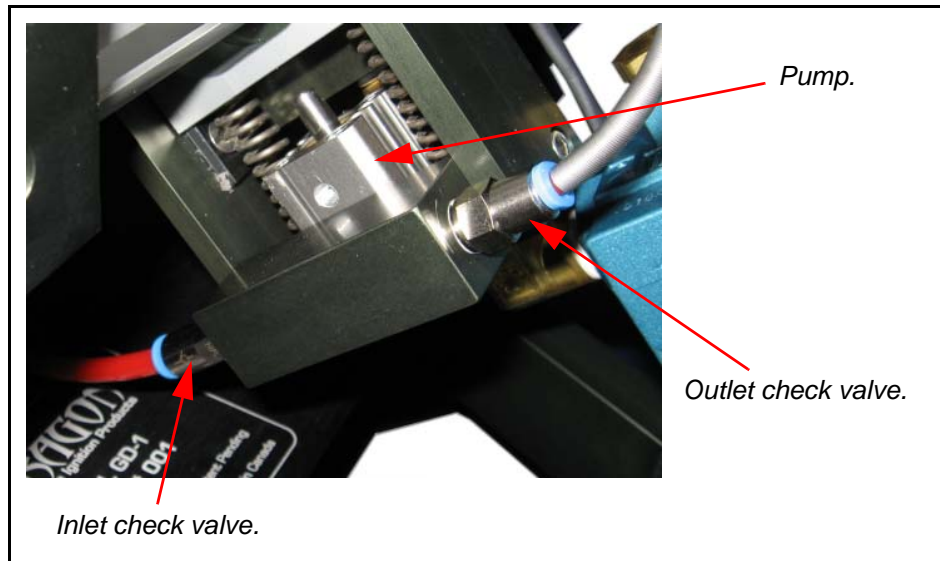

**Glycol System (continued)**

- The glycol pump is a piston type pump operated by the action of the needle shuttle.
- The inlet check valve controls the flow of glycol into the pump from the glycol bottle
- The outlet check valve controls the flow of glycol out of the pump to the injection needle.

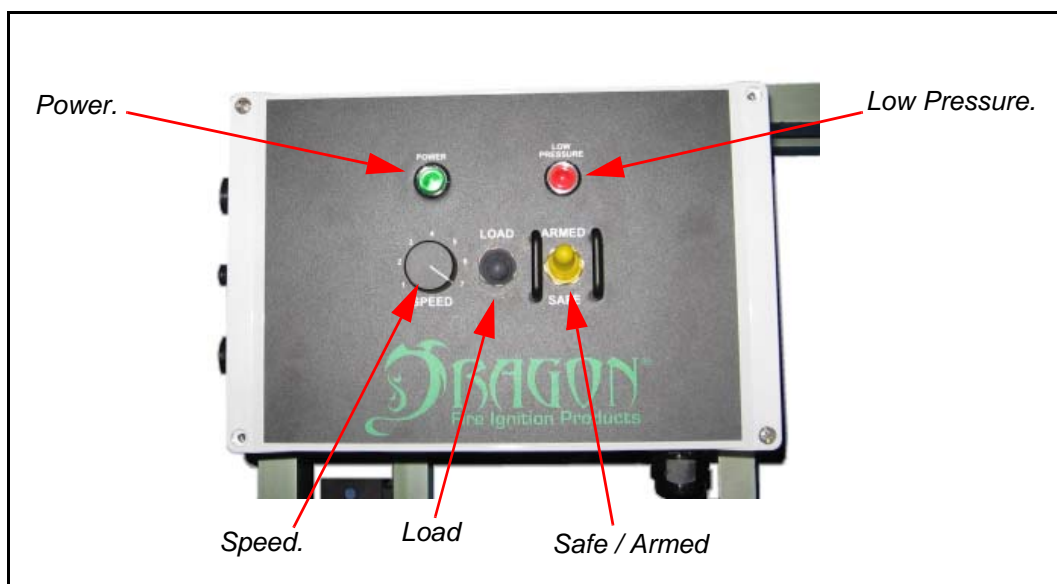
**Main Control Panel**

**Main Control Panel (continued)**

- A resettable circuit breaker is located on the end of the main control panel.
- The power indicator illuminates when the dispenser is connected to external power and the circuit breaker is pushed in.
- The low pressure indicator illuminates when there is insufficient gas pressure to safely operate the dispenser.
- The safe / armed switch is used to prevent trigger signals from activating the dispenser.
- The load switch is used to fill the hopper outlet tube with eggs.
- The speed control varies the cycle speed of launcher when in automatic mode.

**Remote Control**

- The trigger switch is used to initiate an operational cycle of the dispenser.
- The auto/manual switch is used to change between automatic and manual modes of operation.

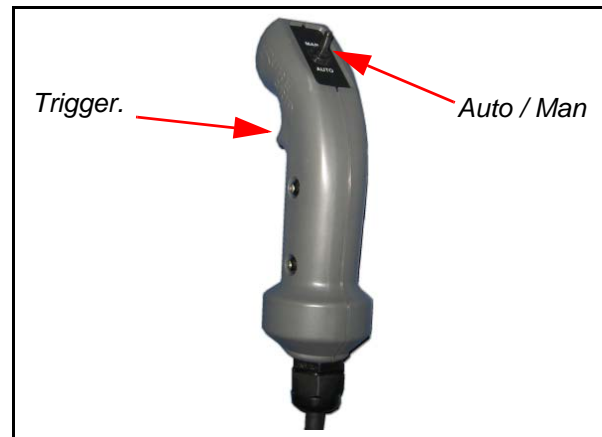
**Power Cord**

- The power cord connects the main control panel to the power adapter.
- The standard power adapter connects the power cord to a user-supplied power source.

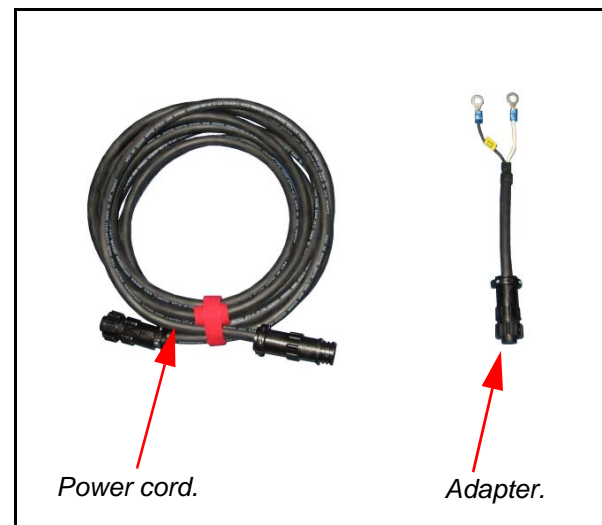

## Principles of Operation

The Green Dragon launcher operates on the principle of a single cycle operation. Each time a cycle is initiated, both the hopper and launcher complete one cycle and stop. When the dispenser is stopped between cycles, there are no charged eggs in the dispenser.

### ***Loading Operation***

Before the launcher can be operated, the outlet tube connecting the hopper and the launcher must be loaded with five eggs. This can be accomplished by pressing and releasing the load switch on the main control panel. The hopper will operate independently for five cycles to load the outlet tube. During this loading process, the launcher will not respond to trigger signals. If the tube remains loaded from previous use, the load operation is not necessary.

### ***Hopper Operation***

At the start of the cycle, the extractor finger strips the egg from the rotor cavity and adds it to the queue of eggs in the outlet tube. Further rotation causes the flexible vanes in the hopper to apply a constant pushing pressure to the eggs in the queue.

Once the rotor cavity passes by the extractor, the selector plate loads another egg from the hopper into the cavity for the next cycle. At the end of its cycle, the hopper reaches its limit switch and stops rotating.

### ***Launcher Operation***

On the first phase of the cycle, the injection needle shuttle is forced downwards by the drive cams. This causes the injection needle to pierce the last egg in the queue. During the final portion of the phase, the injection shuttle pushes down on the piston of the glycol pump, causing it to inject glycol into the egg through the needle.

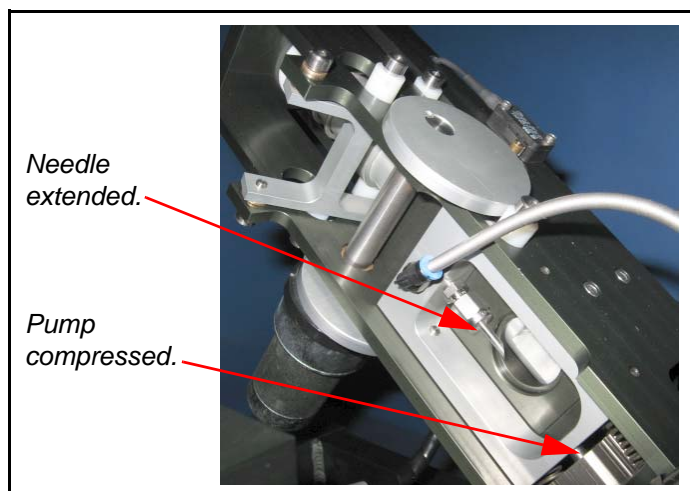

During the second phase of the cycle, the drive cams allow the injection shuttle springs to push the injection shuttle upwards and retract the needle from the egg. The glycol pump returns to its neutral position and recharges with glycol for the next cycle.

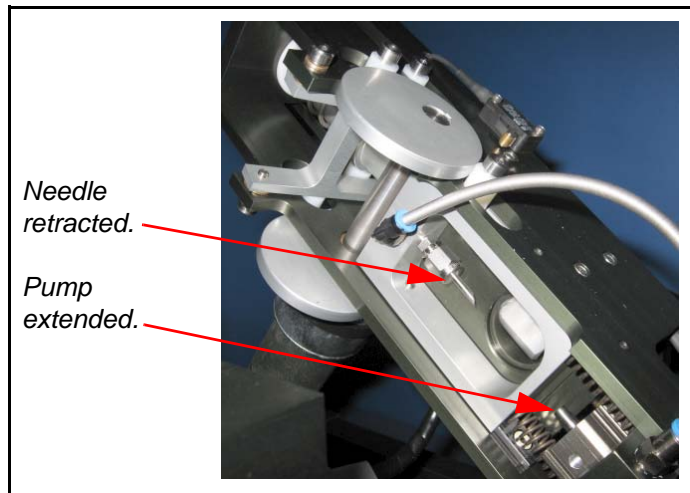

During the third phase of the cycle, the cams push on the barrel actuator, causing the barrel to extend from the receiver. At the end of the stroke, the barrel is fully extended and the side port in the receiver is open. Pressure from the flexible vanes in the hopper pushes the charged egg into the receiver.

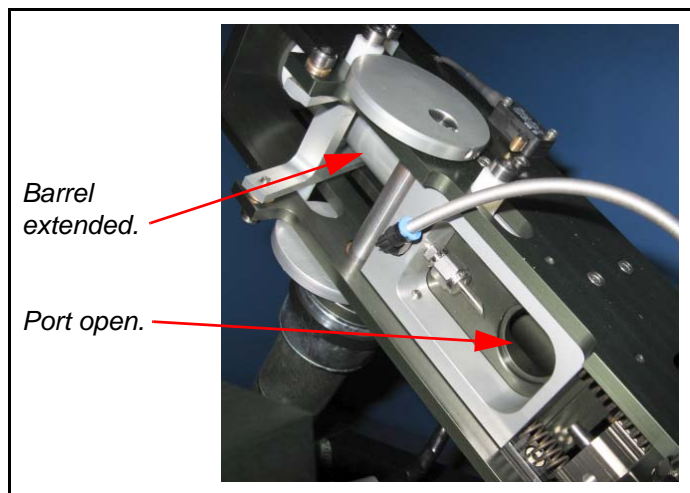

During the final phase of the cycle, the barrel spring forces the barrel to retract to its closed position, closing over the charged egg in the receiver. When the barrel is fully retracted, its lower end seals against an O-ring in the breech. When the cams reach the end of their cycle, they trigger the limit switch.

The limit switch stops the drive motor and sends a signal to the controller to open the shot valve momentarily. The gas charge in the shot tank enters the breech of the barrel and propels the charged egg from the barrel.

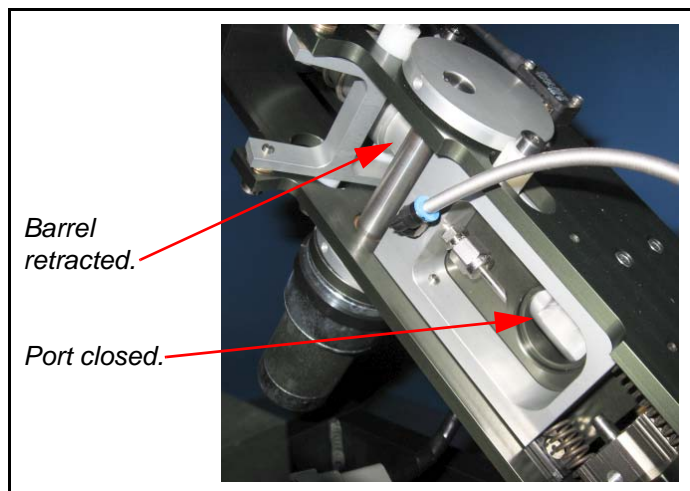

***Modes of Operation***

In the manual mode of operation, each time the trigger is pulled and released, the launcher will complete one cycle and stop. Holding down the trigger will cause the dispenser to continue to cycle at the fastest possible speed until the trigger is released. When released, the dispenser completes the cycle that it has started.

In the automatic mode of operation, the dispenser will cycle continuously without holding down the trigger. In this mode, the trigger is used as a toggle to both start and stop operation. During automatic mode, the speed of operation can be controlled with the speed selector which controls the time delay between cycles.

In either mode of operation, if the gas pressure drops below a preset limit, the launcher will complete its current cycle and then stop. It will not initiate a new cycle until the gas pressure has been restored.





## Section 2: Installation

### Installation

#### *Mounting Options*

The launcher is designed to mount to a variety of vehicle platforms. The most important factor to consider when mounting the launcher is the arc of fire. The launcher has a 180° arc of fire that must face away from the operator.

Typical mounting arrangements are as follows:

- Truck – mounted to the top of the shipping crate facing to the rear.
- ATV – mounted to the rear utility rack facing to the rear.
- UTV – mounted to the front utility rack facing forwards.



### Gas System

If CO<sub>2</sub> gas bottle is used as a propellant, the bottle must be mounted in a vertical position to prevent liquid entering the launcher and causing damage. Mounting brackets are provided to attach a standard 20lb beverage style bottle to the side of the shipping crate.

1. Attach the primary regulator to the gas bottle.
2. Attach the flexible hose to the primary regulator.



3. Connect the flexible hose to the fitting on the manifold.

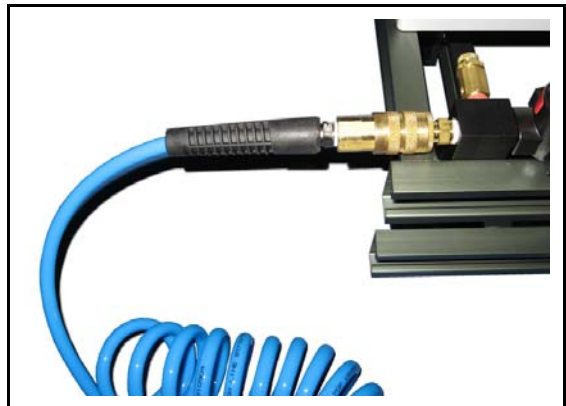

#### CAUTION

Carbon Dioxide (CO<sub>2</sub>) bottles must be used in a vertical position. Failure to do so may cause permanent damage to the launcher.

If using compressed air as a propellant, there are no mounting position restrictions.

### *Electrical System*

The Green Dragon operates on a 12VDC system.

1. Attach the power cord to the receptacle on the control enclosure.

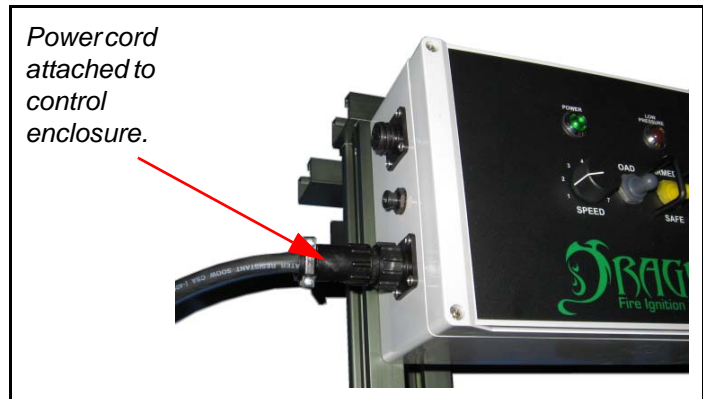

2. Attach the power adapter to the power cord.
3. Attach the power adapter to a 12VDC power supply.
4. Attach the remote control to the receptacle on the control panel.

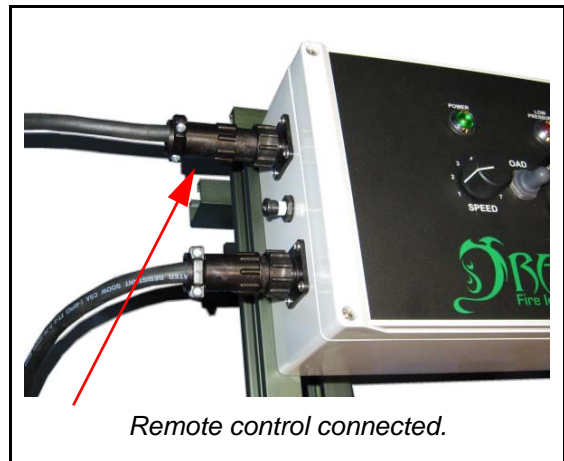

### Glycol System

#### Important Note

Use only 100 per cent ethylene glycol to ensure proper ignition. Do not use 50/50 pre-mix or propylene glycol.

The glycol system uses undiluted ethylene glycol (anti-freeze). To fill and prime the system:

1. Disconnect the glycol supply tube from the glycol bottle by pushing up on the blue ring of the disconnect fitting while pulling down on the tubing.
2. Remove the bottle from the dispenser and fill with ethylene glycol. Replace the bottle and tubing.

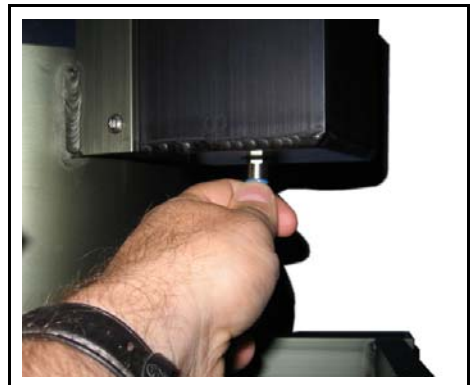

If the launcher has been allowed to run completely out of glycol, it may require priming of the glycol pump.

#### To check the pump priming:

1. Squeeze down on the glycol pump piston.
2. Glycol should squirt out of the injection needle.
3. If it does not, the system requires priming.



***To prime the glycol system:***

1. Remove the glycol supply tubing from the pump inlet check valve and allow the supply tube to fill with glycol.
2. Once the supply tube has filled with glycol, replace the tube into the inlet valve.



3. Squeeze and release the pump piston repeatedly until glycol flows from the injection needle.
4. Wipe up any glycol spills.

***Dragon Eggs***

Observe safe handling practices for the Dragon Eggs. See *Section 8* for the MSDS information.

1. Fill the hopper with Dragon Eggs.



This page left intentionally blank.



## Section 3: Operations

### Green Dragon Operations

To operate the Green Dragon:

1. Press in the circuit breaker.
  - The POWER indicator will illuminate.
  - The LOW PRESSURE indicator will illuminate.



2. Open the valve on the gas bottle or air system, as applicable.
  - The LOW PRESSURE indicator should extinguish.

3. If the outlet tube is empty, press and release the load switch.



4. Adjust the azimuth of the launcher.

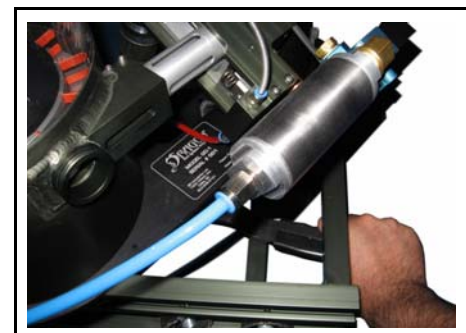

- Adjust the elevation of the launcher.

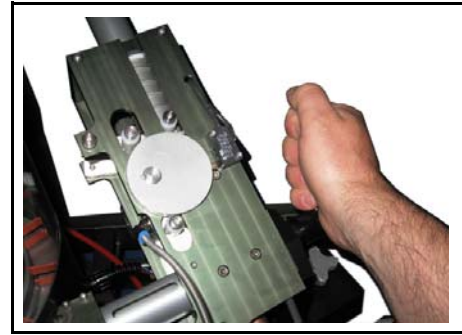

- Select the operational mode using the switch on the remote control.

<b>MAN</b>	<ul style="list-style-type: none"> <li>pull and release the trigger to shoot single eggs.</li> <li>pull and hold the trigger to shoot continuously.</li> </ul>
<b>AUTO</b>	<ul style="list-style-type: none"> <li>pull and release the trigger to start shooting.</li> <li>pull and release the trigger to stop shooting.</li> </ul>



- If in AUTO mode, select the launch speed to get the desired ground spacing.



- Adjust the pressure regulator to give the desired range. Pull up on the locking ring of the pressure regulator before attempting to rotate.

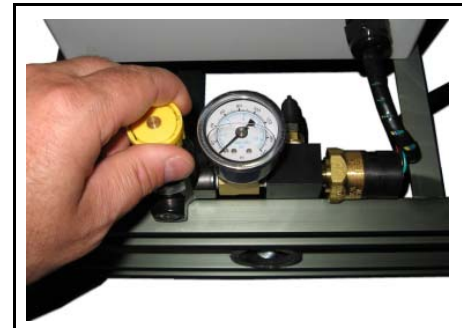



- Set the safety switch to the ARMED position.



- Pull the trigger to initiate operation.

**CAUTION**

The projectiles from the launcher are moving at a high speed and can cause personal injury.

**CAUTION**

Whenever leaving the dispenser unattended, ensure the safety switch is in the SAFE position.

- Add more eggs as required.

**CAUTION**

Do not allow the hopper to run out of eggs. If this occurs, the vanes cannot push the primed egg into the launcher and a fire will result.



This page left intentionally blank.



---

## Section 4: Emergency Procedures

### Launcher Jams

#### Important Note

If a jam occurs in the launcher feed mechanism, it can lead to a fire in the dispenser. If this occurs, extinguish the fire using the supplied water bottle.

#### Clearing a Jam

To facilitate cleaning or clearing a jam, the launcher can be separated from the hopper. The process is as follows:

1. Set the ARMED / SAFE switch to the SAFE position.



2. Turn the slide block knob counter clockwise.

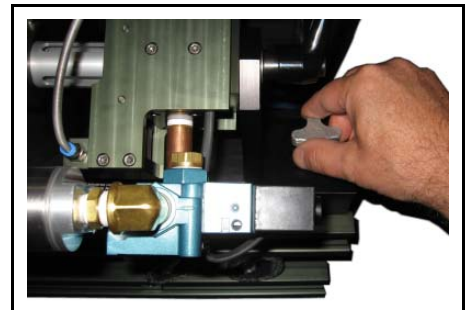

3. Slide the launcher and slide angle away from the hopper.

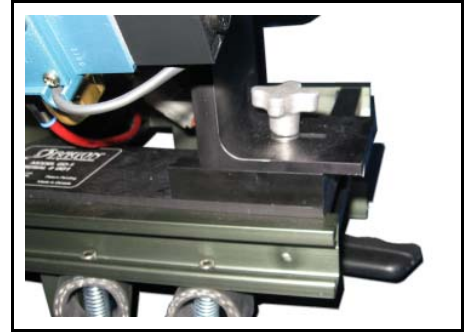

4. Remove the hopper outlet tube.



5. Clean as required.
6. On reassembly, note that there is a slot in the hopper outlet tube which ensures proper alignment with the hopper.

## Section 5: Troubleshooting

These remedial actions are limited to those which can be performed in the field by an operator with limited tools.

### Won't Power On

*Dispenser will not power on and the "POWER" indicator is not illuminated.*

#### **Circuit Breaker**

- Check that the circuit breaker is pushed in.

#### **Faulty Electrical Connection**

- Check that the power supply is properly connected to the power adapter.
- Check that the power adapter is properly connected to the power cord.
- Check that the power cord is properly connected to the receptacle on the control panel.

#### **Power Supply**

- Check that the power supply is 12VDC.
- Check that the power adapter has been attached with the correct polarity.
  - White – Positive
  - Black – Ground

### Won't Load

*Load switch is pushed but hopper does not operate.*

#### **PLC Startup**

When the dispenser first powers on, the internal PLC takes several seconds before it can respond to any inputs.

- Wait five seconds then push load switch again.



**Already Loaded**

The load operation can only be completed once each power cycle.

- Check that the dispenser has not been loaded.
- Pull out the circuit breaker.
- Push in the circuit breaker and wait five seconds.
- Press the load switch.

**Won't Cycle**

*Trigger switch is pulled but dispenser does not respond.*

**PLC Startup**

When the dispenser first powers on, the internal PLC takes several seconds before it can respond to any inputs.

- Wait for five seconds, then pull trigger.

**Load Cycle**

During the load cycle, the dispenser will not respond to trigger signals.

- Wait for loading to complete, then pull trigger.

**Low Gas Pressure**

If the gas pressure is below 30 psi, the dispenser will not cycle and the “LOW PRESSURE” indicator will illuminate.

- Adjust the regulator to increase the pressure above 30 psi.
- Check gas supply.

**Safety On**

If the “SAFE / ARMED” switch is in the “SAFE” position, the dispenser will not respond to trigger signals.

- Set the “SAFE / ARMED” switch to the “ARMED” position.



## Intermittent Operation

*Dispenser shuts down randomly and then restarts.*

### **Power Supply Voltage.**

A low power supply voltage will cause the dispenser to shut down and restart.

- Check that the power supply voltage does not drop below 12VDC during operation.

### **Faulty Electrical Connection**

- Check that the power supply is properly connected to the power adapter.
- Check that the power adapter is properly connected to the power cord.
- Check that the power cord is properly connected to the receptacle on the control panel.

## Egg Jamming

*When dispenser is cycled, eggs do not get loaded into the barrel properly.*

### **Outlet Tube Position**

Incorrect location of the outlet tube will change the position of the eggs in the tube and cause sphere jamming.

- Check that the outlet tube is fully seated into the hopper.
- Check that the outlet tube is fully seated in the counterbore in the receiver.

### **Dirty Outlet Tube**

A dirty outlet tube can cause the eggs to drag in the outlet tube leading to a jam.

- Remove the outlet tube and clean.



---

## Loss of Range

*When dispenser is cycled, eggs are not propelled the normal distance for that pressure setting.*

### **Breech Seal Leakage**

Gas leaking past the o-ring seal in the breech plug will reduce the effective range of the launcher.

- Remove the four socket head cap screws which secure the breech plug to the receiver.
- Remove the breech plug and valve assembly.
- Check breech plug for debris and clean as required.
- Check for damaged or missing o-ring and replace as required.
- Check for damage to the breech end of the barrel and clean as required.

### **Launcher Limit Switch Adjustment**

An improperly adjusted limit switch can cause the cycle to stop too soon and the valve will activate before the barrel is fully seated against the o-ring.

- Cycle the launcher once.
- Check that there is freedom of movement between the barrel actuator frame and the two barrel rollers. This indicates that the barrel is fully seated.
- If required, adjust the launcher limit switch away from the cam to allow the cam to advance further before stopping.

## Ignition Failure

*Eggs are not igniting properly.*

### **Glycol Composition**

Using the wrong type of glycol can cause ignition failure.

- Check that glycol is ethylene glycol and not propylene glycol.
- Check that the glycol has not been diluted with water (automotive antifreeze is often sold as a 50/50 mix of glycol and water).





---

**Ambient Temperature**

The ambient air temperature changes the effect of the reaction.

- Burning, when the ambient air temperature is less than 32°F / 0°C, can cause delayed or poor ignition.

**Injection Needle**

A plugged or damaged injection needle will prevent glycol from entering the eggs.

- Disconnect the glycol outlet line that connects the outlet check valve to the elbow on the needle shuttle.
- Press the needle shuttle to cycle the glycol pump.
- If glycol comes out of the outlet line, then the problem is with the needle.
- Check the needle for blockage and clean as required.

**Glycol Pump System**

Faulty inlet or outlet check valves on the glycol pump will prevent it from pumping glycol.

- Disconnect the glycol inlet line from the bottom of the glycol reservoir (the fitting on the reservoir is self-sealing and will not leak).
- Press the needle shuttle to cycle the glycol pump.
- If the glycol comes out of the inlet line, the inlet check valve is stuck open and needs cleaning or replacing.
- Re-attach the glycol inlet line to the bottom of the glycol reservoir.
- Disconnect the glycol outlet line that connects the outlet check valve to the elbow on the needle shuttle. Seal the end of the glycol outlet line with your thumb.
- Press and release the needle shuttle once to cycle the glycol pump.
- Remove your thumb from the glycol outlet and cycle the pump again.
- If glycol comes out of the outlet line, the outlet check valve is stuck open and needs cleaning or replacing.



This page left intentionally blank.



---

## Section 6: Service

### Cleaning and Storage

Regular cleaning of the Green Dragon is the most important maintenance function. During each operational cycle, a small amount of potassium permanganate powder and glycol can leak out of the punctured hole in the sphere and be deposited in the launcher.

Over the course of thousands of eggs, this can build up and cause feeding problems between the hopper and launcher. Daily and weekly cleaning routines need to be performed to keep the launcher operating reliably.

The recommended cleaners are citrus based solvents such as Simple Green all purpose cleaner. These cleaners do not contain any oils which can cause dust and debris to accumulate in the moving parts of the launcher.

All of the bearing surfaces in the launcher are made from self-lubricating materials. There is no need to lubricate them.

#### ***Daily Cleaning Routine***

- Loosen the slide locking knob and slide the launcher to the right.
- Remove the hopper outlet tube.
- Spray the inside of the outlet tube with cleaner and wipe it as clean as possible. This is the most critical part in the dispenser to be kept clean.
- Pull the barrel outward and spray cleaner into the side port of the receiver. Wipe out as much of the receiver and barrel as is accessible.
- Wipe the needle shuttle and shuttle guides.
- Inspect the injection needle to ensure that it is sharp and straight.
- Wipe up any glycol which has dripped from the breech plug drain port.
- Wipe out the hopper.
- Replace the outlet tube.
- Slide the launcher back to its correct position and lock in place.



---

**Weekly Cleaning Routine**

- Disconnect the air line to the shot tank.



- Disconnect the glycol line to the glycol pump inlet valve.



- Disconnect the electrical connection to the launcher.



- Unscrew the elevation lock handle completely and remove the launcher.

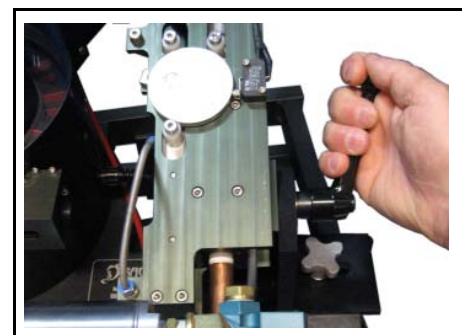

- Remove the four socket head cap screws which secure the front plate to the side plates of the launcher.

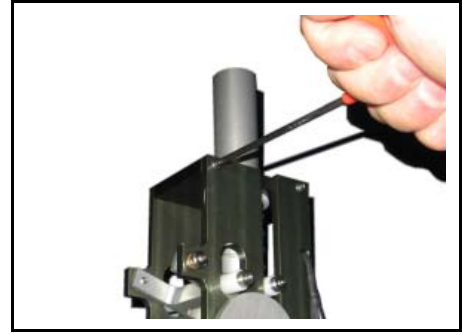

- Remove the front plate, front bearing, barrel and barrel spring.

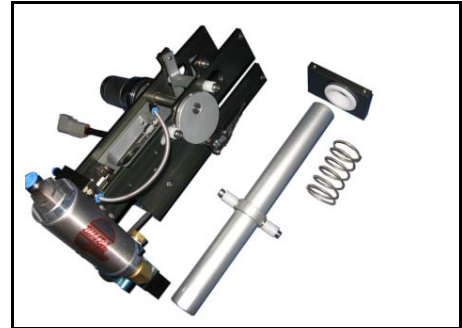

- Wipe out the inside of the front bearing and receiver bearing with a cloth. The bearings are self-lubricating and should not be oiled.

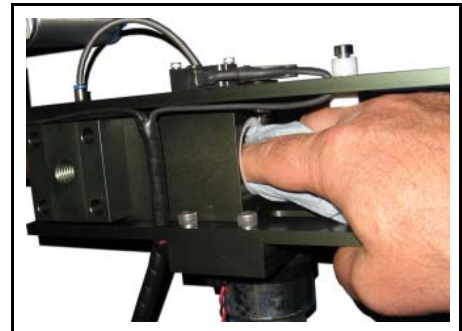

- Spray the inside of the barrel with cleaner and swab out using a cloth.
- Remove the four socket head cap screws which secure the breech plug to the receiver.

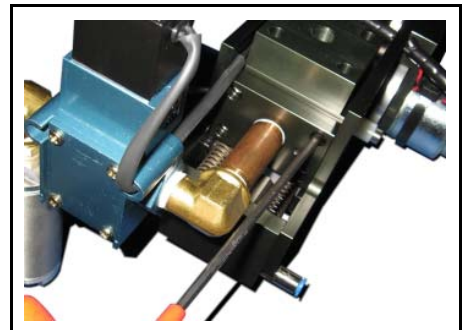

- Remove the breech plug and valve assembly and set aside being careful not to damage the valve wires.

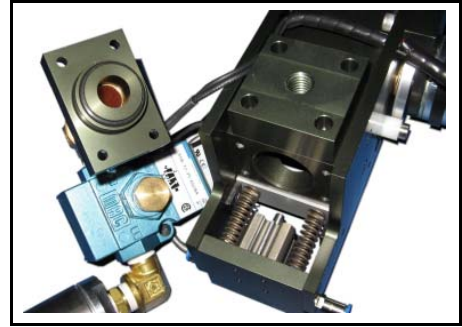

- Remove the o-ring and clean the breech plug paying particular attention to the o-ring groove.

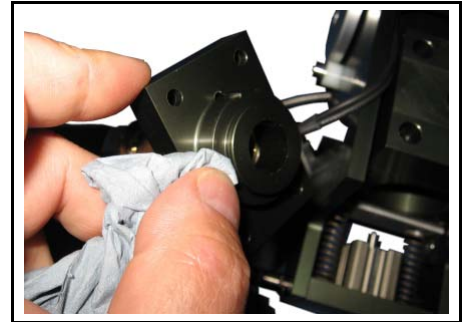

- Clean the o-ring and examine it for signs of damage. It should be soft and pliable. Replace if necessary.
- Spray the bore of the receiver with cleaner and swab it out with a cloth.

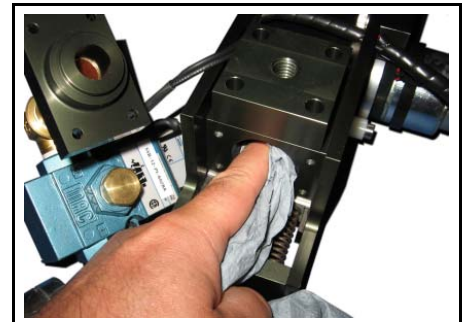

- Clean the port in the side of the receiver where the hopper outlet tube mates.

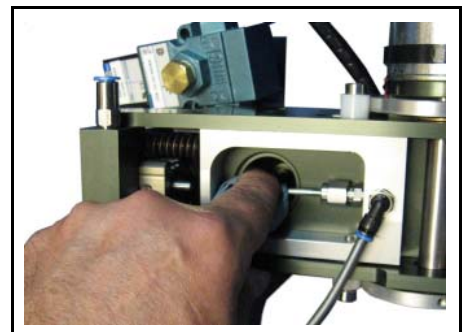

- Wipe the running surfaces of all the nylon bushings on the needle shuttle, barrel actuator and barrel.
- Replace the breech plug and valve assembly into the receiver ensuring the correct orientation. Secure using the four socket head cap screws.
- Install the barrel into the receiver bearing ensuring that the end with the flats is inside of the receiver.
- Install the barrel spring onto the barrel.
- Install the front bearing and front plate into the side plates, ensuring that the flange on the bearing is contacting the barrel spring. Secure using the four socket head cap screws.
- Check the barrel alignment by pulling out the barrel and releasing. If necessary, loosen the cap screws and adjust the front plate to get the optimum alignment.
- Check for damaged vanes in the hopper.

## Storage

Proper packing of the Green Dragon will ensure that no damage occurs to the dispenser during shipping or long term storage.

- Ensure that the dispenser is clean and dry.
- Remove the remote control and place in the hopper.
- Remove the power cord and place in the tool bag.
- Remove the gas hose and place in the tool bag.
- Remove the tank regulator and place in the tool bag.
- Adjust the elevation of the launcher to its highest angle.
- Rotate the hopper and launcher assembly to the position shown.
- Place the dispenser in the crate as shown.
- Close the end of the crate.
- Place the tank hoops in the outer pocket.
- Place the manual in the inner pocket.
- Place the tool bag on the shelf.
- Close the lid and latch the crate.
- Store the crate in a dry location.

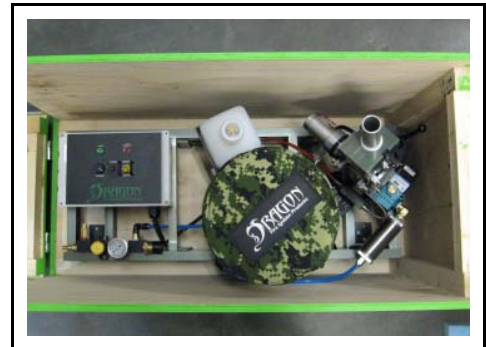

## System Components and Parts Lists

### Base Drawing

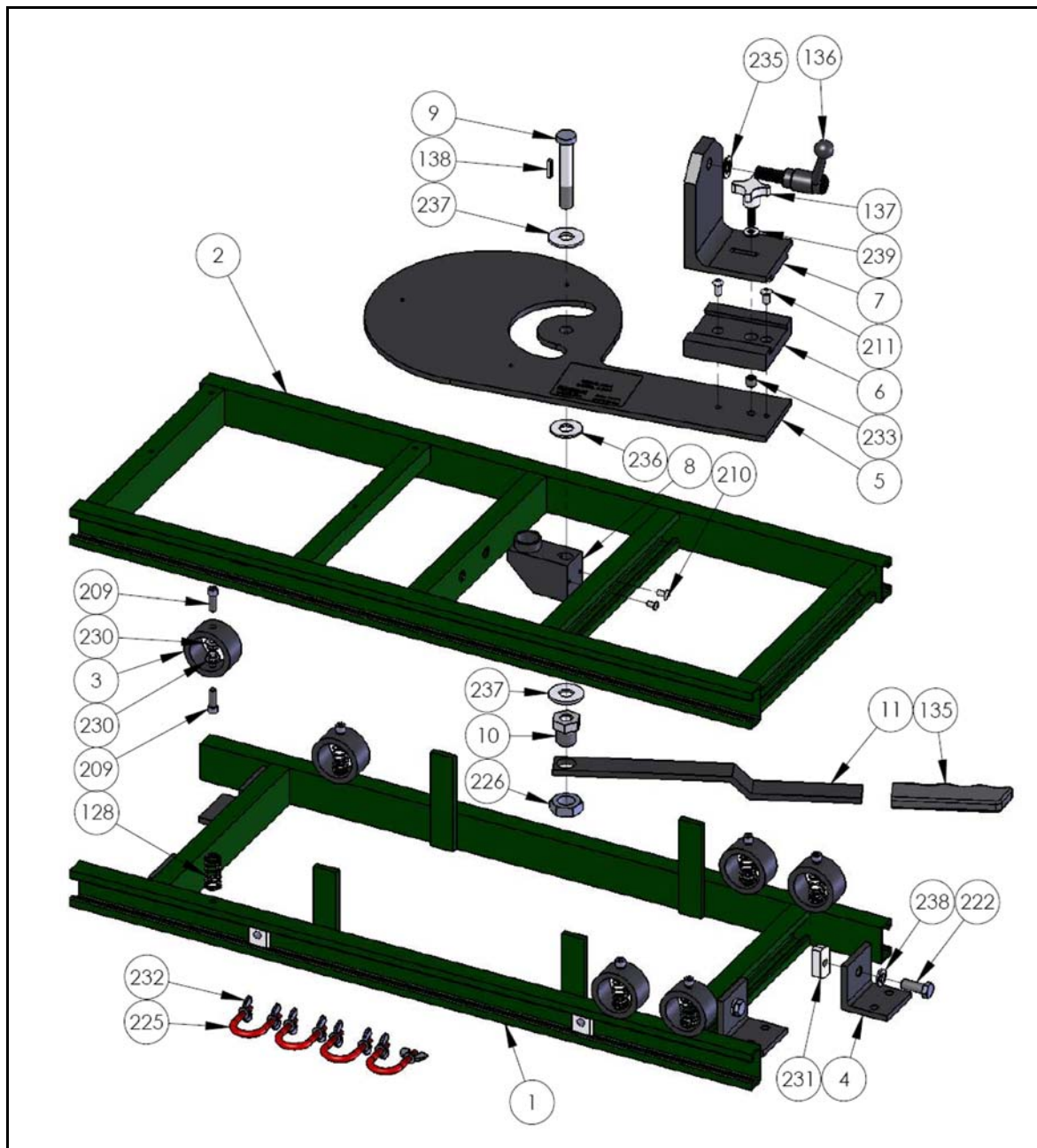



**Base Parts List**

ITEM	PART NUMBER	DESCRIPTION	QTY
1	DE14101	BASE FRAME, LOWER	1
2	DE14102	BASE FRAME, UPPER	1
3	DE14103	VIBRATION ISOLATOR	6
4	DE14104	MOUNT ANGLE, BASE	4
5	DE14110	BASE PLATE	1
6	DE14111	SLIDE BLOCK	1
7	DE14112	SLIDE ANGLE	1
8	DE14113	PIVOT BLOCK	1
9	DE14114	PIVOT PIN	1
10	DE14115	PIVOT NUT	1
11	DE14116	HANDLE, AZIMUTH	1
128	005085	SPRING, COMP, 0.625 x 0.054 x 2.75	6
135	005084	GRIP, 1/4 x 1 x 4, RBR, BLK	1
136	005081	HANDLE, ADJ, MALE, 1/2-13 x 1-3/16	1
137	005082	KNOB, MALE, 1/4-20 x 1-3/4	1
138	005083	KEY, MACHINE, C1018, SQ, 1/8 x 3/4	1
209	000428	SCREW, 1/4-20 x 3/4, SC, SS	12
210	000513	SCREW, 10-24 x 3/8, BC, SS	2
211	000514	SCREW, 1/4-20 x 1/2, BC, SS	2
222	000391	BOLT, 3/8-16 x 1, HX, SS	4
225	000526	U-BOLT, 1/4-20 x 1, PL	4
226	005087	NUT, JAM, 3/4-16, HX, SS	1
230	001647	NUT, FLNG, NYL, 1/4-20, PL	12
231	001648	NUT, CHNL, 3/8-16, PL	8
232	001674	NUT, WING, 1/4-20, SS	8
233	001677	INSERT, THREAD, 1/4-20 x 3/8-24	1
235	001842	WASHER, FLAT, 0.51 x 0.88 x 0.06, SS	1
236	005086	WASHER, FLAT, 0.56 x 1.25 x 0.06, PVC	1
237	001847	WASHER, FLAT, 0.56 x 1.38 x 0.11, SS	2
238	001853	WASHER, LOCK, 3/8, SS	4
239	001819	WASHER, FLAT, 0.28 x 0.63 x 0.06, SS	1

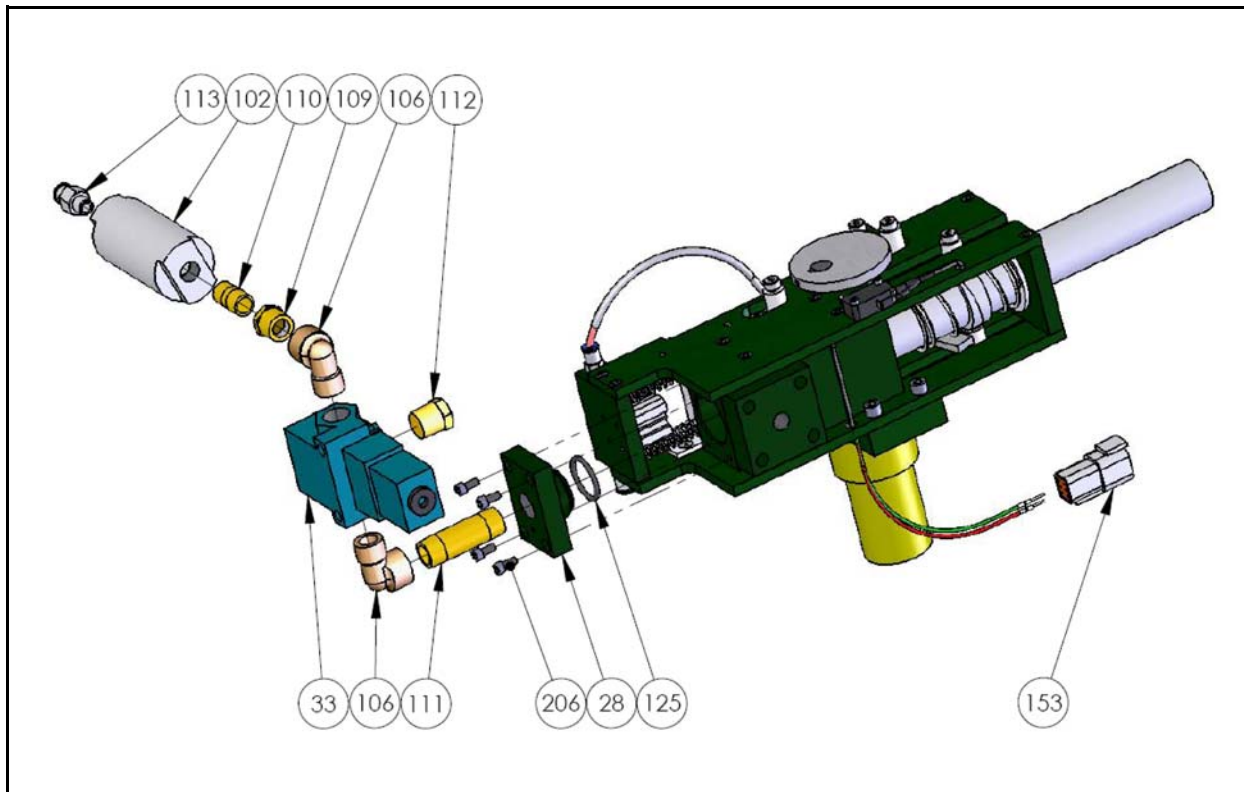

**Launcher Drawings and Parts Lists**

ITEM	PART NUMBER	DESCRIPTION	QTY
28	DE14250	BREECH PLUG	1
33	DE14280	SHOT VALVE	1
102	DE14281	SHOT TANK	1
106	003646	ELBOW, STR90, 3/8NPT, BR	2
109	003632	BUSHING, 3/8MNPT x 1/4FNPT, BR	1
110	003636	NIPPLE, 1/4NPT x CLS, BR	1
111	003637	NIPPLE, 3/8NPT x 2, BR	1
112	005106	PLUG, 3/8 MNPT, HXHD, BR	1
113	003651	ADAPTER, 1/8NPT x 8MM	1
125	005113	O-RING, BUNA N, #119	1
153	001190	RECEPTACLE, FH, 6 PIN	1
206	000418	SCREW, 8-32 x 3/8, SC, SS	4

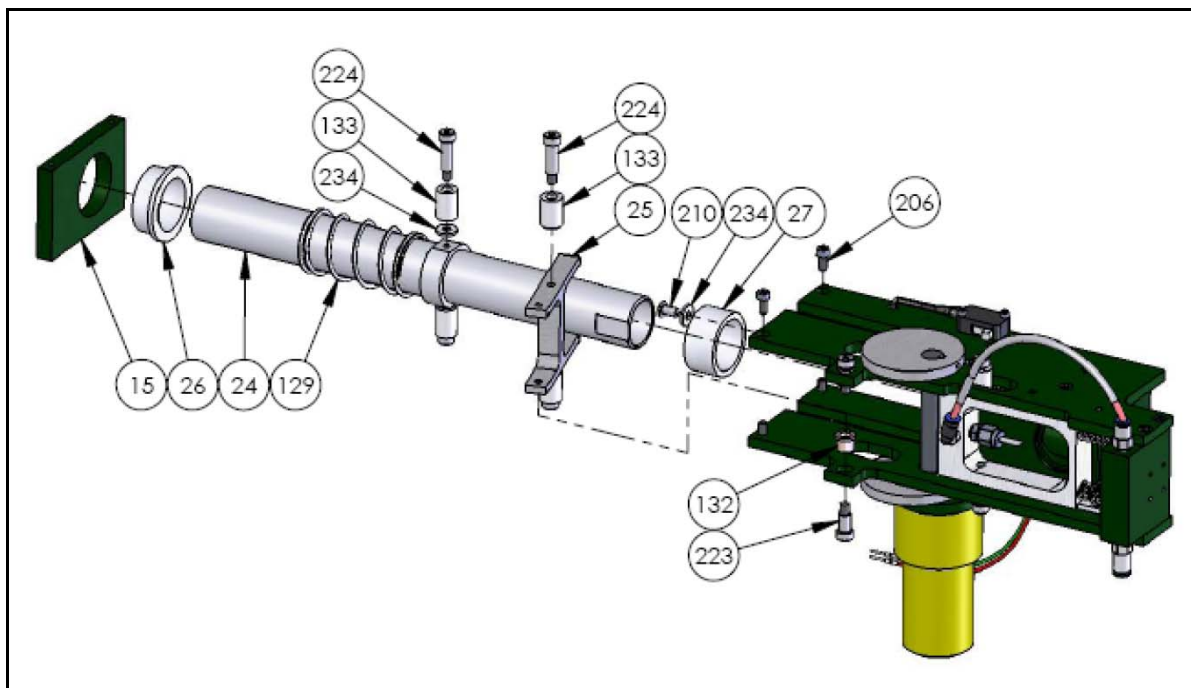
**Launcher Drawings and Parts Lists (continued)**

ITEM	PART NUMBER	DESCRIPTION	QTY
15	DE14204	FRONT PLATE	1
24	DE14240	BARREL	1
25	DE14241	BARREL ACTUATOR	1
26	DE14242	BEARING, FRONT	1
27	DE14243	BEARING, RECEIVER	1
129	005111	SPRING, COMP, 1.500 x 0.091 x 2.63	1
132	005108	BUSHING, FL, BRZ, 1/4 x 3/8 x 3/8	2
133	005104	BUSHING, ST, NY, 1/4 x 1/2 x 11/16	4
206	000418	SCREW, 8-32 x 3/8, SC, SS	4
210	000513	SCREW, 10-24 x 3/8, BC, SS	1
223	003685	BOLT, 1/4 x 7/16 x 10-32, SH, HX, SS	2
224	000557	BOLT, 1/4 x 3/4 x 10-32, SH, HX, SS	4
234	001843	WASHER, FLAT, 0.20 x 0.50 x 0.06, SS	3

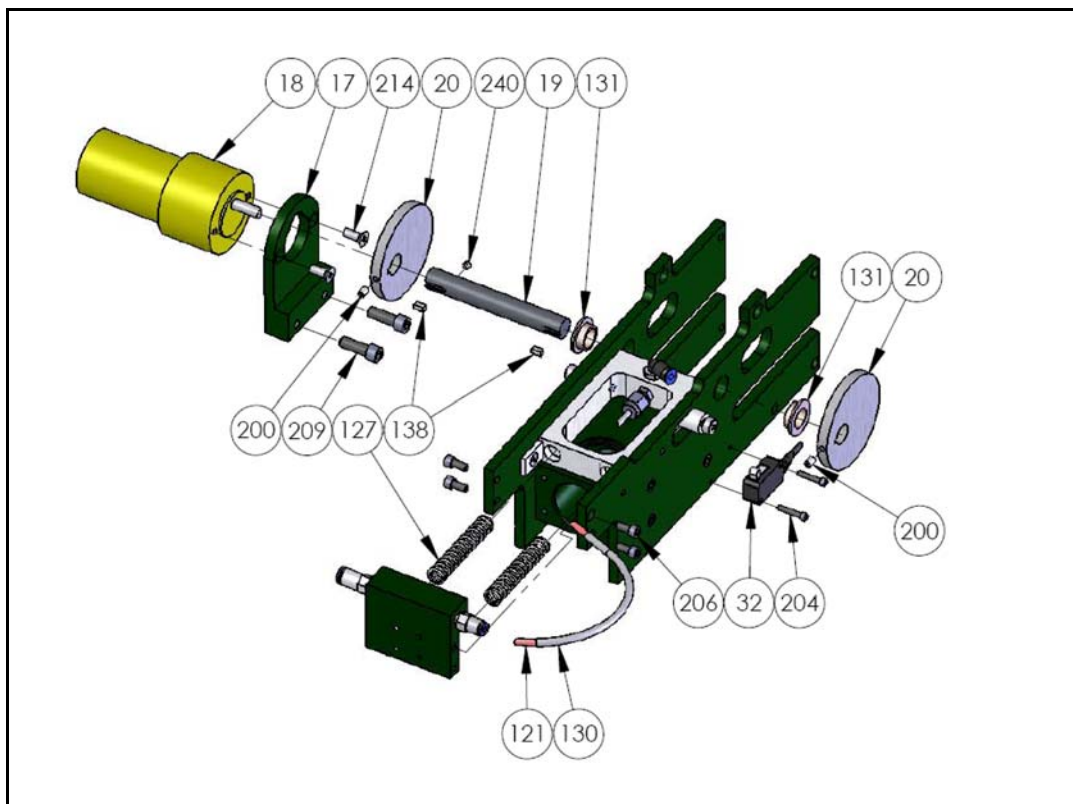
**Launcher Drawings and Parts Lists (continued)**

ITEM	PART NUMBER	DESCRIPTION	QTY
17	DE14220	MOTOR MOUNT	1
18	DE14221	MOTOR, LAUNCHER	1
19	DE14222	DRIVE SHAFT	1
20	DE14223	CAM	2
32	DE14270	LIMIT SWITCH, LAUNCHER	1
121	004217	TUBE, PUN, 4MM x 0.75MM, RED	8 IN
127	005110	SPRING, COMP, 0.420 x 0.051 x 2.25	2
130	006072	SPRING, EXT, 0.188 x 0.015 x 20.0	7 IN
131	005109	BUSHING, FL, BRZ, 1/2 x 5/8 x 1/4	2
138	005083	KEY, MACHINE, C1018, SQ, 1/8 x 3/4	2
200	000364	SETSCREW, 8-32 x 1/4, CUP, SS	2
204	000405	SCREW, 4-40 x 5/8, SC, SS	2
206	000418	SCREW, 8-32 x 3/8, SC, SS	4
209	000428	SCREW, 1/4-20 x 3/4, SC, SS	2
214	000538	SCREW, 10-32 x 1/2, MS, FHPH, SS	2
240	000363	SETSCREW, 8-32 x 1/8, CUP, SS	1

**Launcher Drawings and Parts Lists (continued)**

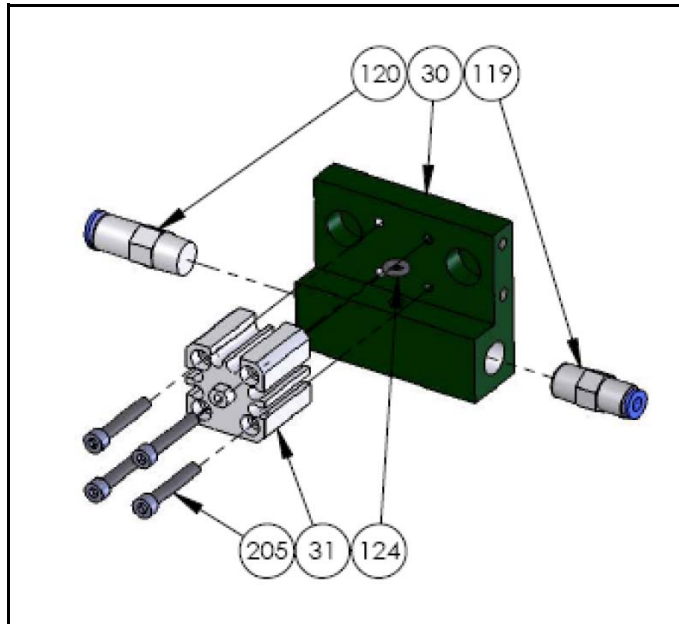

ITEM	PART NUMBER	DESCRIPTION	QTY
30	DE14261	PUMP MANIFOLD	1
31	DE13223	GLYCOL PUMP	1
119	004228	VALVE, NON-RETURN, 1/8MNPT -> 4MM	1
120	004230	VALVE, NON-RETURN, 6MM -> 1/8MNPT	1
124	005112	O-RING, BUNA N, #007	1

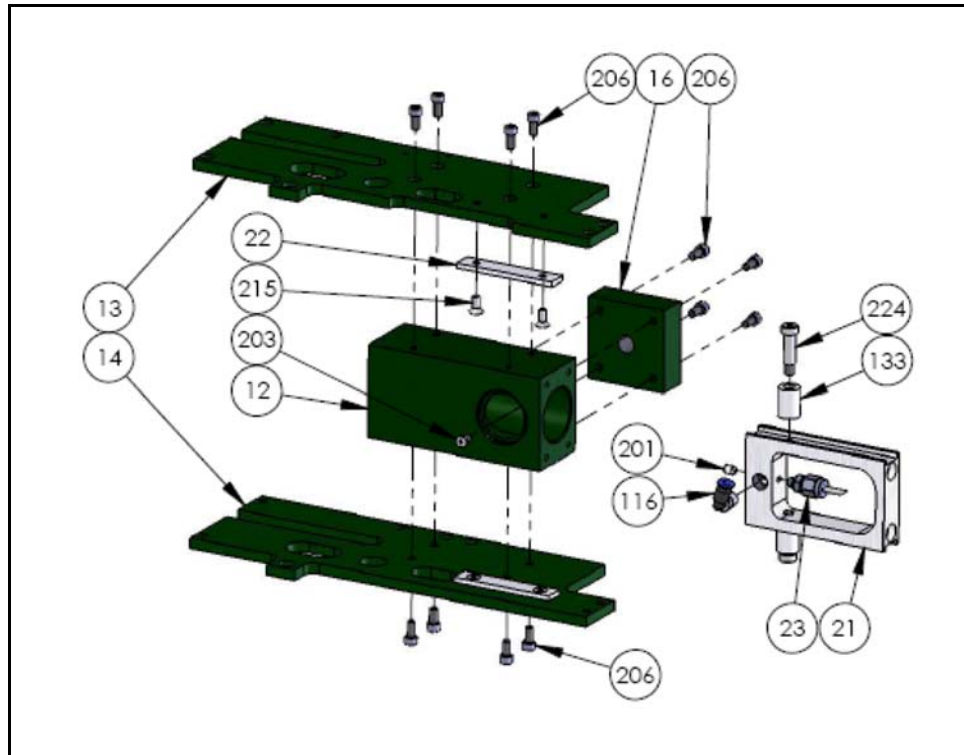
**Launcher Drawings and Parts Lists (continued)**

ITEM	PART NUMBER	DESCRIPTION	QTY
12	DE14201	RECEIVER	1
13	DE14202	UPPER FRAME	1
14	DE14203	LOWER FRAME	1
16	DE14210	TRUNNION BLOCK	1
21	DE14230	NEEDLE SHUTTLE	1
22	DE14231	SHUTTLE GUIDE	2
23	DE14232	NEEDLE ASSEMBLY	1
116	003643	ELBOW, STR90, 1/8NPT x 4MM	1
133	005104	BUSHING, ST, NY, 1/4 x 1/2 x 11/16	2
201	000525	SETSCREW, 10-32 x 1/4, CUP, SS	1
203	005238	SCREW, 8-32 x 1/4, LSC, SS	1
206	000418	SCREW, 8-32 x 3/8, SC, SS	12
215	000444	SCREW, 8-32 x 3/8, FSC, SS	4
224	000557	BOLT, 1/4 x 3/4 x 10-32, SH, HX, SS	2

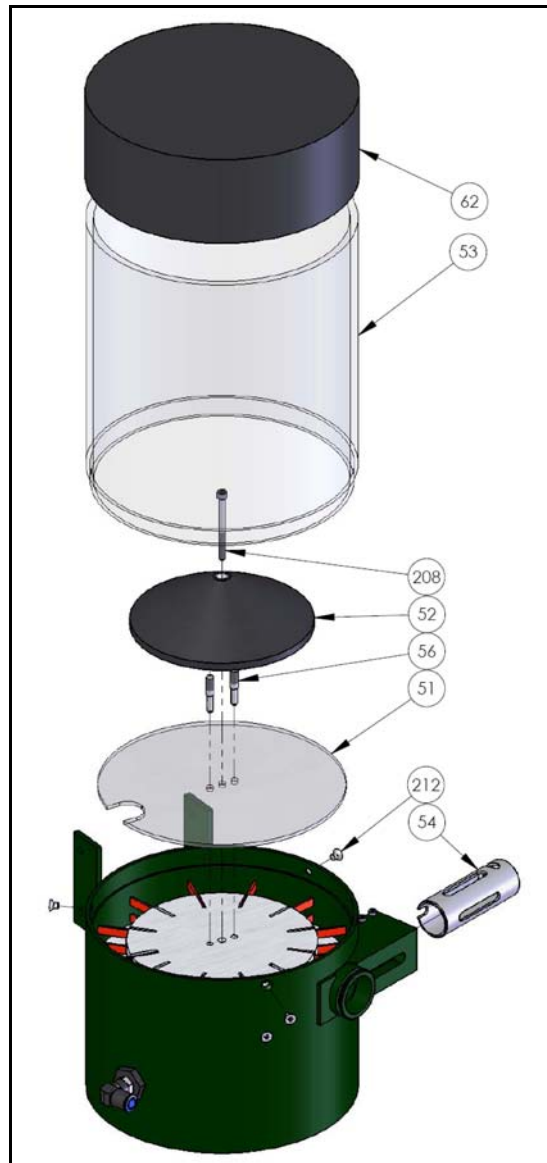

**Hopper Drawings and Parts Lists**

ITEM	PART NUMBER	DESCRIPTION	QTY
51	DE14533	SELECTOR PLATE	1
52	DE14534	CONICAL DEFLECTOR	1
53	DE14540	HOPPER TUBE	1
54	DE14541	OUTLET TUBE	1
56	DE13526	LOCATE PIN, HOPPER	2
62	DE14970	COVER, HOPPER	1
208	000552	SCREW, 10-24 x 2-1/4, SC, SS	1
212	000448	SCREW, 10-24 x 1/4, MS, FHPH, SS	3

*Hopper Drawings and Parts Lists (continued)*

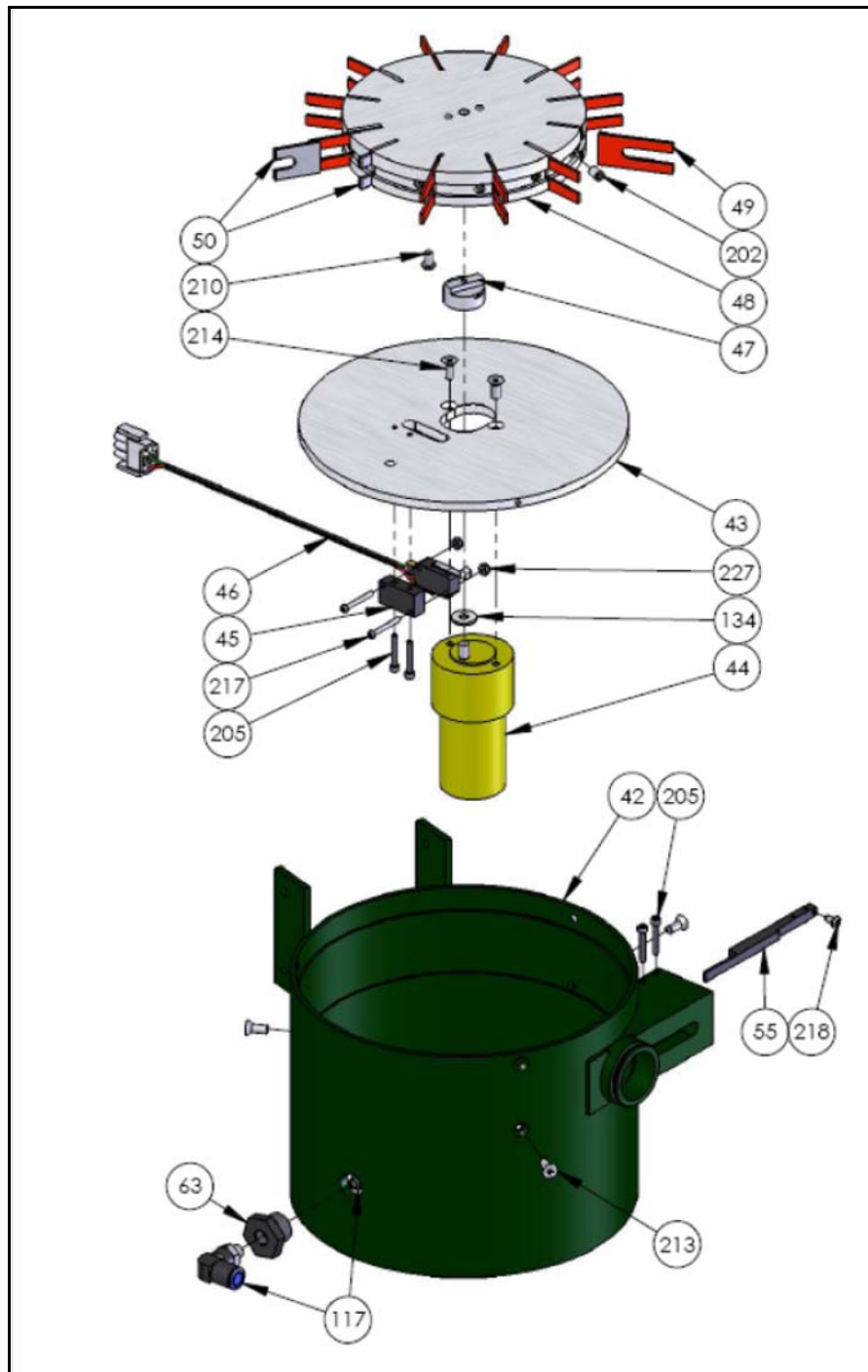



**Hopper Parts List (2)**

ITEM	PART NUMBER	DESCRIPTION	QTY
42	DE14510	HOPPER BASE	1
43	DE14520	MOTOR PLATE	1
44	DE14521	MOTOR, HOPPER	1
45	DE14522	BLOCK, MICROSWITCH	1
46	DE14523	LIMIT SWITCH, HOPPER	1
47	DE14524	MOTOR COUPLING	1
48	DE14530	ROTOR	1
49	DE14531	VANE, FLEXIBLE	12
50	DE14532	VANE, RIGID	2
55	DE14542	EXTRACTOR	1
63	DE14302	ADAPTER, HOPPER	1
117	003649	ELBOW, STR90, 1/8NPT x 8MM	2
134	005138	BUSHING, ST, NY, 1/4 x 5/8 x 1/16	1
202	005151	SCREW, 1/4-20 x 3/8, SET, CUP, SS	12
205	000414	SCREW, 6-32 x 7/8, SC, SS	4
210	000513	SCREW, 10-24 x 3/8, BC, SS	1
213	000446	SCREW, 10-24 x 1/2, MS, FHPH, SS	3
214	000538	SCREW, 10-32 x 1/2, MS, FHPH, SS	2
217	000477	SCREW, 4-40 x 1, MS, PNPH, SS	2
218	000481	SCREW, 6-32 x 1/4, MS, PNPH, SS	1
227	001657	NUT, NYL, 4-40, HX, SS	2



**Gas Manifold Drawing and Parts List**

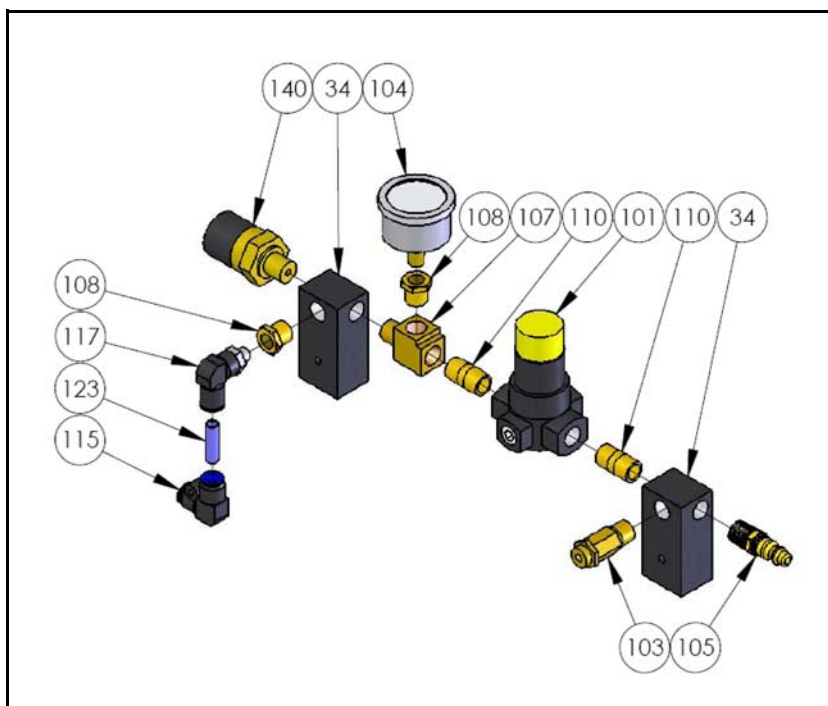

ITEM	PART NUMBER	DESCRIPTION	QTY
34	DE14301	GAS MANIFOLD	1
101	005131	REGULATOR, GAS, 2-125PSI, 1/4 NPT	1
103	005133	VALVE, RELIEF, 25-200PSI, 1/4NPT	1
104	005132	GAUGE, PRES, 0-160PSI, 1/8 NPT	1
105	003639	ADAPTER, QUICK x 1/4MNPT	1
107	003640	TEE, STR, 1/4MNPT x 1/4FNPT	1
108	003631	BUSHING, 1/4MNPT x 1/8FNPT, BR	2
110	003636	NIPPLE, 1/4NPT x CLS, BR	2
115	003642	ELBOW, 8MM	1
117	003649	ELBOW, STR90, 1/8NPT x 8MM	1
123	004220	TUBE, PUN, 8MM x 1.25MM, BLU	1 IN
140	001310	PRES SWITCH, SPDT, 0-30PSI, 1/4 NPT	1

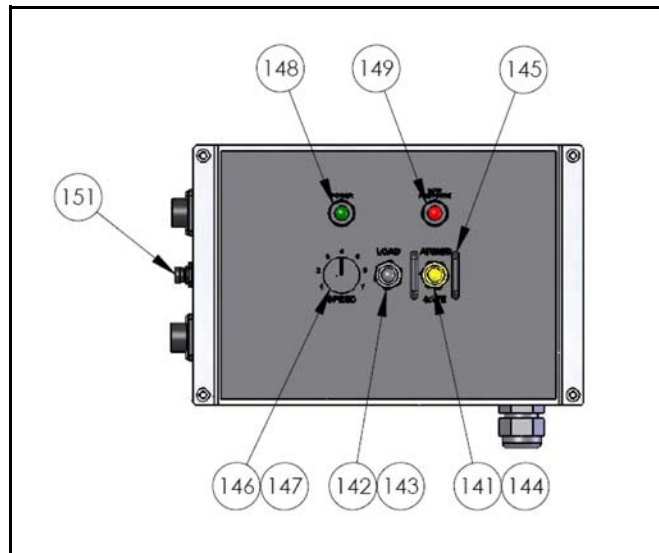
**Control Panel Drawing and Parts List**

ITEM	PART NUMBER	DESCRIPTION	QTY
141	001369	SWITCH, TOGGLE, SPST, 15A, 125VAC	1
142	005095	SWITCH, TOGGLE, SPST, 20A, 125VAC	1
143	001355	BOOT, TOGGLE SWITCH, 15/32, GRY	1
144	006022	BOOT, TOGGLE SWITCH, 15/32, YEL	1
145	005139	SWITCH GUARD, 1 x 1, 4-40	2
146	005094	POTENTIOMETER, 5K OHM, 1/2 W	1
147	001368	KNOB, ABS, 0.85 DIA, 1/4 SHAFT	1
148	001303	LED, 12VDC, 700MCD, GRN	1
149	001302	LED, 12VDC, 700MCD, RED	1
151	000896	BREAKER, CIRCUIT, 3A	1

*Simplified Electrical Schematic*

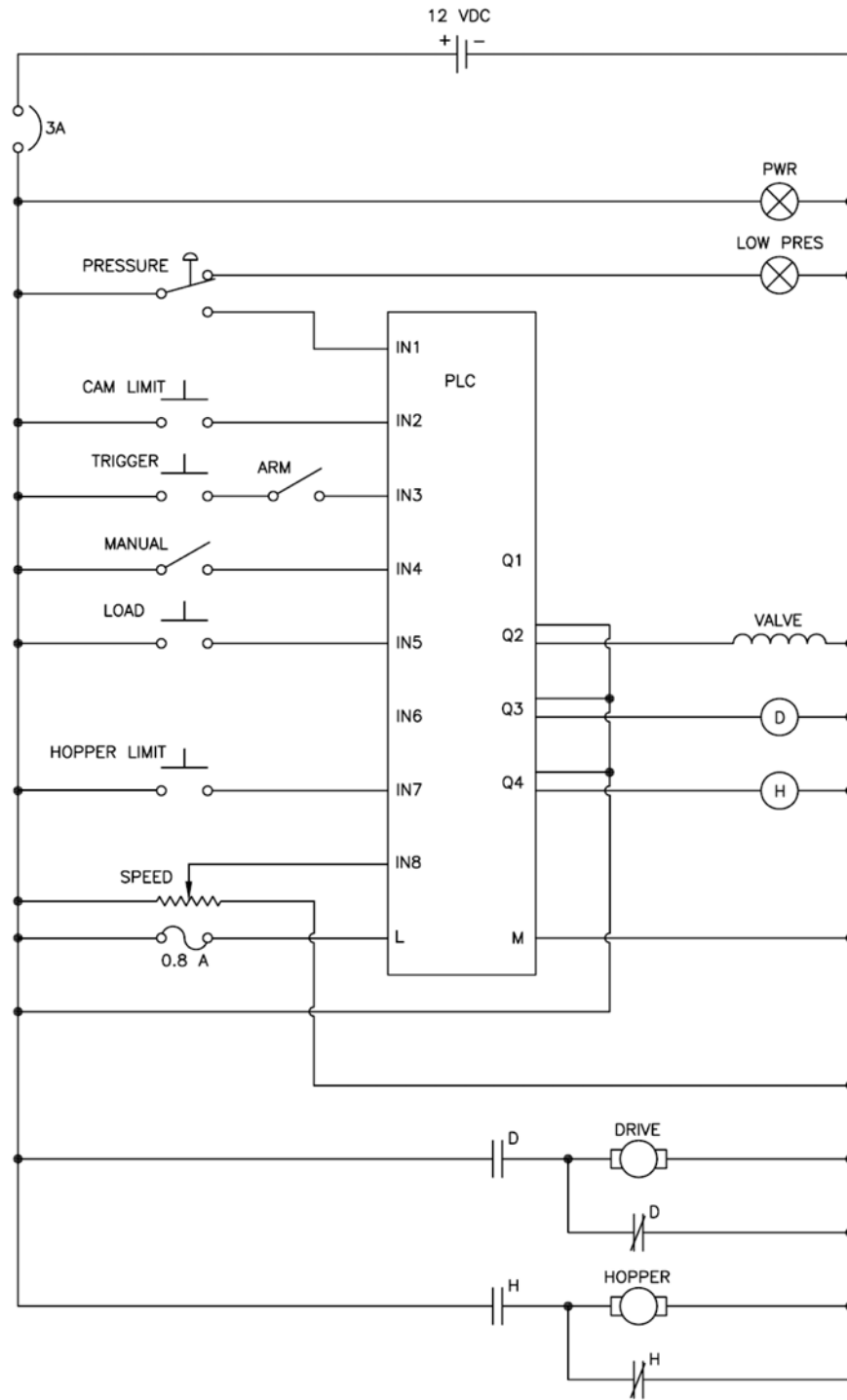

*Simplified Pneumatic Schematic*

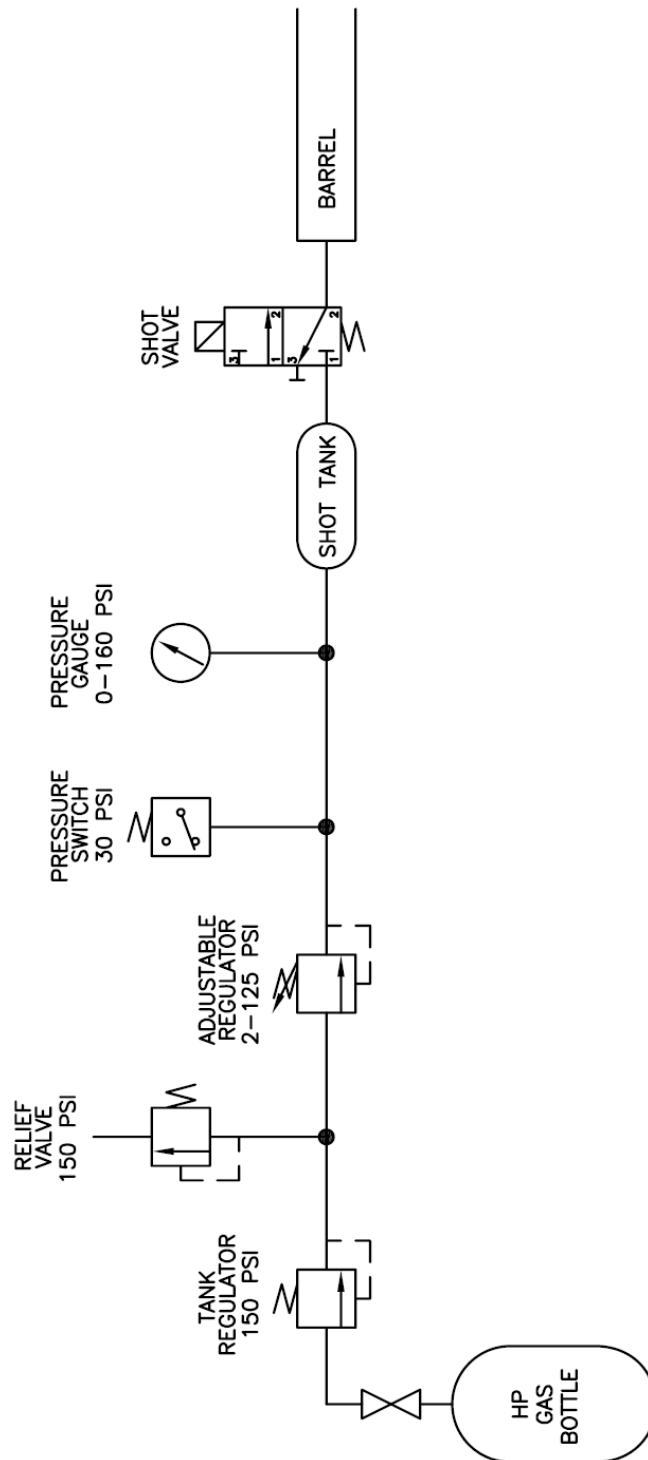

## Parts Cross Reference List

The purpose of this section is to provide a cross reference to alternate parts suppliers for the non-proprietary components used in the dispenser. The item number in the table corresponds to the item number used in the expanded drawings in this section of the manual.

Item	Description	Supplier	Part Number
101	REGULATOR, GAS, 2-125PSI, 1/4 NPT	McMaster Carr	41735K11
103	VALVE, RELIEF, 25-200PSI, 1/4NPT	McMaster Carr	50265K23
104	GAUGE, PRES, 0-160PSI, 1/8 NPT	McMaster Carr	9780T11
105	ADAPTER, QUICK x 1/4MNPT	Greenline	CP21B
106	ELBOW, STR90, 3/8NPT, BR	Greenline	G1698B-06-06
107	TEE, STR, 1/4MNPT x 1/4FNPT	Greenline	G16T88B-04-04
108	BUSHING, 1/4MNPT x 1/8FNPT, BR	Greenline	G0816B-04-02
109	BUSHING, 3/8MNPT x 1/4FNPT, BR	Greenline	G0816B-06-04
110	NIPPLE, 1/4NPT x CLS, BR	Greenline	G1616BC-04
111	NIPPLE, 3/8NPT x 2, BR	Greenline	G1616B-06X2
112	PLUG, 3/8 MNPT, HXHD, BR	Greenline	G1600B-06
113	ADAPTER, 1/8NPT x 8MM	Festo	153004
114	ADAPTER, QUICK, 1/8MNPT x 6MM	Festo	153420
115	ELBOW, 8MM	Festo	153072
116	ELBOW, STR90, 1/8NPT x 4MM	Festo	153334
117	ELBOW, STR90, 1/8NPT x 8MM	Festo	153048
119	VALVE, NON-RETURN, 1/8MNPT -> 4MM	Festo	153446
120	VALVE, NON-RETURN, 6MM -> 1/8MNPT	Festo	153449
121	TUBE, PUN, 4MM x 0.75MM, RED	Festo	178410
122	TUBE, PUN, 6MM x 1MM, RED	Festo	178411
123	TUBE, PUN, 8MM x 1.25MM, BLU	Festo	159666
124	O-RING, BUNA N, #007	McMaster-Carr	2418T113
125	O-RING, BUNA N, #119	McMaster-Carr	2418T144
126	VENT, 1/8MNPT, BR	McMaster-Carr	9833K21
127	SPRING, COMP, 0.420 x 0.051 x 2.25	Century Spring	71395
128	SPRING, COMP, 0.625 x 0.054 x 2.75	McMaster-Carr	9657K127
129	SPRING, COMP, 1.500 x 0.091 x 2.63	Century Spring	S-1263
130	SPRING, EXT, 0.188 x 0.015 x 20.0	McMaster Carr	9665K53
132	BUSHING, FL, BRZ, 1/4 x 3/8 x 3/8	McMaster-Carr	6338K412
133	BUSHING, ST, NY, 1/4 x 1/2 x 11/16	McMaster-Carr	94638A251
134	BUSHING, ST, NY, 1/4 x 5/8 x 1/16	McMaster-Carr	96371A202
135	GRIP, 1/4 x 1 x 4, RBR, BLK	McMaster-Carr	9692K15
136	HANDLE, ADJ, MALE, 1/2-13 x 1-3/16	McMaster-Carr	6271K46
137	KNOB, MALE, 1/4-20 x 1-3/4	McMaster-Carr	6085K310
138	KEY, MACHINE, C1018, SQ, 1/8 x 3/4	McMaster-Carr	98870A100
140	PRES SWITCH, SPDT, 0-30PSI, 1/4 NPT	Newark	42M0461
141	SWITCH, TOGGLE, SPST, 15A, 125VAC	Newark	04M4765
142	SWITCH, TOGGLE, SPST, 20A, 125VAC	Digikey	480-3068-ND
143	BOOT, TOGGLE SWITCH, 15/32, GRY	Newark	30F000
144	BOOT, TOGGLE SWITCH, 15/32, YEL	Newark	95B1098
145	SWITCH GUARD, 1 x 1, 4-40	McMaster Carr	1568A41



**Parts Cross Reference List (continued)**

146	POTENTIOMETER, 5K OHM, 1/2 W	Digikey	CT3012-ND
147	KNOB, ABS, 0.85 DIA, 1/4 SHAFT	Newark	91F2244
148	LED, 12VDC, 700MCD, GRN	Newark	93K6718
149	LED, 12VDC, 700MCD, RED	Newark	93K6719
150	RELAY, SPDT, 12VDC, 40A	Newark	30M9185
151	BREAKER, CIRCUIT, 3A	Flame	2TC2-3
152	FUSE, 1/4 x 1-1/4, 0.8A, 250V	Newark	48K9415
200	SETSCREW, 8-32 x 1/4, CUP, SS	Fastenal	73225
201	SETSCREW, 10-32 x 1/4, CUP, SS	Fastenal	73245
202	SCREW, 1/4-20 x 3/8, SET, CUP, SS	Fastenal	73258
203	SCREW, 8-32 x 1/4, LSC, SS	Fastenal	171396
204	SCREW, 4-40 x 5/8, SC, SS	Fastenal	73405
205	SCREW, 6-32 x 7/8, SC, SS	Fastenal	73417
206	SCREW, 8-32 x 3/8, SC, SS	Fastenal	73421
207	SCREW, 8-32 x 1/2, SC, SS	Fastenal	73422
208	SCREW, 10-24 x 2-1/4, SC, SS	Fastenal	73433
209	SCREW, 1/4-20 x 3/4, SC, SS	Fastenal	73480
210	SCREW, 10-24 x 3/8, BC, SS	Fastenal	73742
211	SCREW, 1/4-20 x 1/2, BC, SS	Fastenal	73767
212	SCREW, 10-24 x 1/4, MS, FHPH, SS	Fastenal	72660
213	SCREW, 10-24 x 1/2, MS, FHPH, SS	Fastenal	72662
214	SCREW, 10-32 x 1/2, MS, FHPH, SS	Fastenal	72682
215	SCREW, 8-32 x 3/8, FSC, SS	Fastenal	73851
216	SCREW, 4-40 X 3/8, MS, PNP, SS	Fastenal	72482
217	SCREW, 4-40 x 1, MS, PNP, SS	Fastenal	72494
218	SCREW, 6-32 x 1/4, MS, PNP, SS	Fastenal	72383
219	SCREW, 8-32 X 3/8, MS, PNP, SS	Fastenal	72396
220	SCREW, 10-24 X 3/8, MS, PNP, SS	Fastenal	72438
221	SCREW, 10-24 x 3/4, MS, PNP, SS	Fastenal	72442
222	BOLT, 3/8-16 x 1, HX, SS	Fastenal	77105
223	BOLT, 1/4 x 7/16 x 10-32, SH, HX, SS	McMaster Carr	93996A845
224	BOLT, 1/4 x 3/4 x 10-32, SH, HX, SS	McMaster Carr	94035A540
225	U-BOLT, 1/4-20 x 1, PL	Fastenal	42004
226	NUT, JAM, 3/4-16, HX, SS	Fastenal	70837
227	NUT, NYL, 4-40, HX, SS	Fastenal	70854
228	NUT, NYL, 8-32, HX, SS	Fastenal	70856
229	NUT, JAM, NYL, 10-24, HX, SS	Fastenal	129154
230	NUT, FLNG, NYL, 1/4-20, PL	Fastenal	37337
231	NUT, CHNL, 3/8-16, PL	McMaster-Carr	3259T32
232	NUT, WING, 1/4-20, SS	Fastenal	70910
233	INSERT, THREAD, 1/4-20 x 3/8-24	McMaster-Carr	94165A435
234	WASHER, FLAT, 0.20 x 0.50 x 0.06, SS	Fastenal	71010
235	WASHER, FLAT, 0.51 x 0.88 x 0.06, SS	McMaster-Carr	98017A210
236	WASHER, FLAT, 0.56 x 1.25 x 0.06, PVC	McMaster-Carr	95611A033
237	WASHER, FLAT, 0.56 x 1.38 x 0.11, SS	Fastenal	71022
238	WASHER, LOCK, 3/8, SS	Fastenal	71067



## Section 7: Specifications

### Dispenser Specifications

Min. launch rate	12 eggs per min.
Max. launch rate	40 eggs per min.
Range	75 yds.    70 m
Hopper capacity	450 eggs
Power Supply	12 VDC
Operational weight	49.0 lbs    22 kg
Glycol Volume	0.26 US gal 1.0 liter

### Dragon Egg Specifications

<i>Dragon Egg Weight</i>	.17 oz    4.8 g
<i>Box of 1,000 Dragon Eggs</i>	12.1 lbs    5.5 kg
Injection to the first combustion (smoke)	25 seconds @ 55° F (13° C)
Injection to full combustion (flame)	35 seconds @ 55° F (13° C)
Total useful combustion time	80 seconds @ 55° F (13° C)

#### Important Note

Increasing ambient temperatures will decrease the ignition delay time.





### Safety

Although stable, prior to priming with ethylene glycol, the material within the sealed Dragon Egg is classified as a hazardous substance and, as such, must be handled and transported in the correct manner. Potassium permanganate ( $\text{KMnO}_4$ ) is a strong oxidizer and will react violently with certain chemicals as indicated below. In addition, potassium permanganate should not be inhaled or otherwise absorbed or come in contact with the skin.

#### WARNING

There are dangerous compounds that must be isolated from the potassium permanganate in Dragon Eggs during shipping and storage. These compounds include:



Antimony	Aluminium Carbide
Arsenic	Ethylene Glycol
Glycerol	Hydrogen Trisulphide
Hydrogen Peroxide	Phosphorous
Sulphur	Sulphuric Acid
Titanium	

A full MSDS sheet for the chemical is included in the appendix.

### Dragon Egg Shipping Box Certifications

- The complete package has been tested to meet the requirements of ISTA procedure 1A.
- The complete package has been tested to meet the requirements of UN 4G combination packaging.





	<h1>CAIROX<sup>®</sup> Potassium Permanganate</h1> <p>EC- SAFETY DATA SHEET is prepared according to the latest adaptations to (CLP) Regulations (EC) No 1272/2008 and (EC) No 1907/2006.</p> <p style="text-align: right;"><b>Material Safety Data Sheet</b> Page 1 of 11</p>	
	<p>This product is distributed by Canada Colors and Chemicals Limited General Inquiry: (905) 459-1232 24 Hour Emergency: (416) 444-2112 CCC: Product Code: <b>754506</b> CCC: Product Name: POT. PERMANGANATE BP GRADE</p> 	
MSDS # CP-103	Revision Date: November 2010	Supersedes: August 2010

## Section 1 Identification of the Substance/Preparation and of the Company/Undertaking

<b>SUBSTANCE/PREPARATION NAME:</b> Potassium permanganate, KMnO <sub>4</sub> <b>PRODUCT NAME:</b> CAIROX <sup>®</sup> Potassium Permanganate <b>TRADE NAME:</b> CAIROX <sup>®</sup> Potassium Permanganate <b>SYNONYMS:</b> Permanganic acid potassium salt, Chameleon mineral, Condy's crystal, Permanganate of potash	
<b>USES OF SUBSTANCE:</b> Potassium Permanganate is an oxidant recommended for applications that require a strong oxidant.	
<b>COMPANY NAME (Europe):</b> CARUS EUROPE	<b>COMPANY ADDRESS:</b> C/ Secundino Roces, 3-Planta 1 <sup>a</sup> – Oficina 14, 33428 Cayes – Llanera, Asturias - Spain  <b>INFORMATION:</b> + (34) 985-785-513 <b>EMERGENCY TELEPHONE:</b> + (34) 985-785-513
<b>COMPANY NAME (US):</b> CARUS CORPORATION	<b>COMPANY ADDRESS:</b> 315 Fifth Street Peru, IL 61354, USA  <b>INFORMATION:</b> (815) 223-1500 (815) 224-6816 (FAX) <a href="http://www.caruscorporation.com">www.caruscorporation.com</a> (Web) <a href="mailto:salesmkt@caruscorporation.com">salesmkt@caruscorporation.com</a> (Email)  <b>EMERGENCY TELEPHONE:</b> (800) 435-6856 (USA) (815) 223-1500 (Other countries) (800) 424-9300 (CHEMTREC <sup>®</sup> , USA) (703) 527-3887 (CHEMTREC <sup>®</sup> , Other countries)

## Section 2 Hazards Identification

<b><u>GLOBAL HARMONIZED SYSTEM (GHS) OF CLASSIFICATION OF THE SUBSTANCE</u></b> Oxidizing solid, Category 2 Acute toxicity, Category 4 Aquatic toxicity (acute), Category 1 Aquatic toxicity (chronic), Category 1	
<b><u>GHS LABEL ELEMENTS, INCLUDING PRECAUTIONARY STATEMENTS</u></b> <b>Signal Word: DANGER</b> <b>Label Codes: GHS03, GHS07, GHS09</b> <b>Hazard Statements: H272, H302, H400, H410</b>	
  	
H272	May intensify fire, oxidizer
H302	Harmful, if swallowed
H410	Very toxic to aquatic life with long lasting effects
P210	Keep away from heat/sparks/open flames/hot surfaces. – No smoking
P220	Keep/Store away from clothing/combustible materials.
P260	Do not breathe dust
P280	Wear protective gloves/protective clothing/eye protection/face protection
P370 + P378	In case of fire: Use water for extinction
P501	Dispose of contents/container to appropriate places
P273	Avoid release to the environment.



# CAIROX<sup>®</sup> Potassium Permanganate

EC- SAFETY DATA SHEET according to Regulation (EC) № 1272/2008 of the European Parliament and of the Council, of 16 December 2008 and amending Regulation (EC) No. 1907/2007 concerning REACH

Material Safety Data Sheet  
Page 2 of 11

MSDS # CP-103

Revision Date: November 2010

Supercedes: August 2010

## Section 2 Hazards Identification (contd.)

### EU CLASSIFICATION

HAZARD SYMBOLS: O, Xn, N

RISK PHRASES: 8,22, 50/53

### HUMAN AND ENVIRONMENTAL HAZARDS

Contact with combustible material may cause fire.

Harmful if swallowed.

Very toxic to aquatic organisms may cause long-term adverse effects in the aquatic environment.

This substance is hazardous in the European Union according to the latest adaptations to Regulations (EC) No 1272/2008 and (EC) No 1907/2006.

### OTHER HAZARDS

#### EYE CONTACT

Potassium Permanganate is damaging to eye tissue on contact. It may cause burns that result in damage to the eye.

#### SKIN CONTACT

Momentary contact of solution at room temperature may be irritating to the skin, leaving brown stains. Prolonged contact is damaging to the skin. Concentrated solutions at elevated temperature and crystals are damaging to the skin.

#### INHALATION

Acute inhalation toxicity data are not available. However, airborne concentrations of potassium permanganate in the form of dust or mist may cause damage to the respiratory tract.

#### INGESTION

Potassium Permanganate, if swallowed, may cause burns to mucous membranes of the mouth, throat, esophagus, and stomach.

### HAZARDOUS MATERIALS IDENTIFICATION SYSTEM (HMIS) RATINGS

Health: 1 - Slight

Flammability: 0 - None

Reactivity: 0 - None

Personnel Protective Equipment: goggles face shield, apron, respirator and proper gloves.

## Section 3 Composition/Information on Ingredients

CAS#	Component / EC#	Percent	Symbols	Risks
7722-64-7	Potassium permanganate 231-760-3	>97.5	Xn N O	8,22, 50/53

### Component Related Regulatory Information

This product may be regulated, have exposure limits or other information identified as the following: Permanganates, inorganic, n.o.s., Manganese compounds, inorganic

#### Substance Registration Number(s)

This material is produced in amounts > 1 tonne/annum and is therefore subject to REACH registration.

01-2119480139-34-0000



# CAIROX<sup>®</sup> Potassium Permanganate

EC- SAFETY DATA SHEET according to Regulation (EC) № 1272/2008 of the European Parliament and of the Council, of 16 December 2008 and amending Regulation (EC) No. 1907/2007 concerning REACH

Material Safety Data Sheet

Page 3 of 11

MSDS # CP-103

Revision Date: November 2010

Supercedes: August 2010

## Section 4 First Aid Measures

### EYES

Immediately flush eyes with large amounts of water for at least 15 minutes holding lids apart to ensure flushing of the entire surface. Do not attempt to neutralize chemically. Seek medical attention immediately. **Note to physician:** Decomposition products are alkaline. Insoluble decomposition product formed is brown colored manganese dioxide.

### SKIN

Immediately wash contaminated areas with water. Remove contaminated clothing and footwear. Wash clothing and decontaminate footwear before reuse. Seek medical attention immediately if irritation is severe or persistent.

### INHALATION

Remove person from contaminated area to fresh air. If breathing has stopped, resuscitate and administer oxygen if readily available. Seek medical attention immediately.

### INGESTION

Never give anything by mouth to an unconscious or convulsing person. If person is conscious, give large quantities of water. Seek medical attention immediately.

### NOTE TO PHYSICIANS

For inhalation, consider oxygen.

Avoid gastric lavage or emesis.

Decomposition products are alkaline. Insoluble decomposition product formed is brown colored manganese dioxide.

## Section 5 Fire Fighting Measures

### NFPA\* HAZARD SIGNS

Health Hazard	1	=	Materials that under emergency conditions, can cause significant irritation. Materials that on the skin could cause irritation.
Flammability Hazard	0	=	Materials that will not burn under typical fire conditions, including intrinsically noncombustible materials such as concrete, stone and sand.
Instability Hazard	0	=	Materials that in themselves are normally stable, even under fire conditions.
Special Hazard	OX	=	Oxidizer

\*National Fire Protection Association 704 (USA)

### FIRST RESPONDERS

Wear protective gloves, boots, goggles, and respirator. In case of fire, wear positive pressure breathing apparatus. Approach incident with caution.

### FLASHPOINT

None

### FLAMMABLE OR EXPLOSIVE LIMITS

Lower: Nonflammable Upper: Nonflammable

### EXTINGUISHING MEDIA

Use large quantities of water. Water will turn pink to purple when in contact with potassium permanganate. Dike to contain. Do not use dry chemicals, CO<sub>2</sub>, Halon<sup>®</sup> or foams, because they are not effective.

### SPECIAL FIREFIGHTING PROCEDURES

If material is involved in fire, flood with water. Cool all affected containers with large quantities of water. Apply water from as far a distance as possible. Wear self-contained breathing apparatus and full protective clothing.



# CAIROX<sup>®</sup> Potassium Permanganate

EC- SAFETY DATA SHEET according to Regulation (EC) № 1272/2008 of the European Parliament and of the Council, of 16 December 2008 and amending Regulation (EC) No. 1907/2007 concerning REACH  
Material Safety Data Sheet  
Page 4 of 11

MSDS # CP-103

Revision Date: November 2010

Supercedes: August 2010

## Section 5 Fire Fighting Measures (contd.)

### UNUSUAL FIRE AND EXPLOSION

Powerful oxidizing material. May decompose spontaneously if exposed to heat (135°C / 275°F). May be explosive in contact with certain other chemicals (Section 10). May react violently with finely divided and readily oxidizable substances. Increases burning rate of combustible material.

### THERMAL DECOMPOSITION PRODUCTS:

**Combustion:** oxides of potassium, oxides of manganese. Fire may product irritating, poisonous and/or corrosive fumes.

## Section 6 Accidental Release Measures

### OCCUPATIONAL SPILL/RELEASE

Avoid contact with combustible materials. Do not touch spilled material. Move containers away from spill to a safe area. Keep unnecessary people away, isolate hazard area and deny entry.

### PERSONAL PRECAUTIONS

Ensure adequate ventilation. Avoid dust formation. Personnel should wear protective clothing suitable for the task. Remove all ignition sources and incompatible materials before attempting clean up.

### ENVIRONMENTAL PRECAUTIONS

Do not flush into sanitary sewer system or surface water. If accidental release into the environment occurs, inform the responsible authorities. Keep the product away from drains, sewers, surface and ground water and soil.

### STEPS TO BE TAKEN IF MATERIAL IS RELEASED OR SPILLED

Clean up spills immediately by sweeping or shoveling up the material. Do not return spilled material to the original container; transfer to a clean metal or plastic drum. To clean up potassium permanganate solutions, follow either of the following two options.

Option # 1: Dilute to approximately 6% with water, and then reduce with sodium thiosulfate, a bisulfite or ferrous salt solution. The bisulfite or ferrous salt may require some dilute sulfuric acid (10% w/w) to promote reduction. Neutralize with sodium carbonate to neutral pH, if acid was used. Decant or filter and deposit sludge in approved landfill. Where permitted, the sludge may be drained into sewer with large quantities of water.

Option # 2: Absorb with inert media like diatomaceous earth or inert floor dry, collect into a drum and dispose of properly. Does not use saw dust or other incompatible media. Disposal of all materials shall be in full and strict compliance with all federal, state, and local regulations pertaining to permanganates.

To clean contaminated floors, flush with abundant quantities of water into sewer, if permitted by federal, state, and local regulations. If not, collect water and treat as described above.

## Section 7 Handling and Storage

### WORK/HYGIENIC PRACTICES

Wash hands thoroughly with soap and water after handling potassium permanganate. Do not eat, drink or smoke when working with potassium permanganate. Wear proper protective equipment. Remove clothing if it becomes contaminated.

### VENTILATION REQUIREMENTS

Provide sufficient mechanical and/or local exhaust to maintain exposure below the TLV/TWA.

### CONDITIONS FOR SAFE STORAGE

Store in accordance with NFPA 430 requirements for the Storage of Class II oxidizing materials. Protect containers from physical damage. Store in a cool, dry area in closed containers. Segregate from acids, peroxides, formaldehyde, and all combustible, organic, or easily oxidizable materials including antifreeze and hydraulic fluid.



# CAIROX<sup>®</sup> Potassium Permanganate

EC- SAFETY DATA SHEET according to Regulation (EC) № 1272/2008 of the European Parliament and of the Council, of 16 December 2008 and amending Regulation (EC) No. 1907/2007 concerning REACH  
Material Safety Data Sheet  
Page 5 of 11

MSDS # CP-103

Revision Date: November 2010

Supercedes: August 2010

## Section 8 Exposure Controls and Personal Protection

### COMPONENT EXPOSURE LIMITS

Potassium permanganate (7722-64-7)

ACGIH: 0.2 mg/m<sup>3</sup> TWA (as Mn)

### VENTILATION

Provide local exhaust or process enclosure ventilation system. Ensure compliance with applicable exposure limits.

### PERSONAL PROTECTIVE EQUIPMENT

#### EYES/FACE

Face shield, goggles, or safety glasses with side shields should be worn. Provide eyewash in working area.

#### GLOVES

Rubber or plastic gloves should be worn.

### OTHER PROTECTIVE EQUIPMENT

Chemically resistant clothing covering arms and legs, and rubber or plastic apron should be worn. **Caution:** If clothing becomes contaminated, wash off immediately.

### RESPIRATORY PROTECTION

In cases where overexposure to dust may occur, the use of an approved NIOSH-MSHA dust respirator or an air supplied respirator is advised. Engineering or administrative controls should be implemented to control dust.

Measurement Element: Manganese (Mn)

#### 10 mg/m<sup>3</sup>

Any particulate respirator equipped with an N95, R95, or P95 filter (including N95, R95, and P95 filtering facepieces) except quarter-mask respirators. The following filters may also be used: N99, R99, P99, N100, R100 or P100.

Any supplied-air respirator.

#### 25 mg/m<sup>3</sup>

Any supplied-air respirator operated in a continuous-flow mode.

Any powered, air-purifying respirator with a high-efficiency particulate filter.

#### 50 mg/m<sup>3</sup>

Any air-purifying, full-facepiece respirator equipped with an N100, R100, or P100 filter.

Any supplied-air respirator with a tight-fitting face piece that is operated in a continuous-flow mode.

Any powered, air-purifying respirator with a tight-fitting face piece and a high-efficiency particulate filter.

Any self-contained breathing apparatus with a full face piece.

Any supplied-air respirator with a full face piece.

#### 500 mg/m<sup>3</sup>

Any supplied-air respirator operated in a pressure-demand or other positive-pressure mode.

Emergency or planned entry into unknown concentrations or IDLH conditions -

Any self-contained breathing apparatus that has a full face piece and is operated in a pressure-demand or other positive-pressure mode.

#### Escape

Any air-purifying, full-face piece respirator equipped with an N100, R100, or P100 filter.

Any appropriate escape-type, self-contained breathing apparatus.



# CAIROX<sup>®</sup> Potassium Permanganate

EC- SAFETY DATA SHEET according to Regulation (EC) № 1272/2008 of the European Parliament and of the Council, of 16 December 2008 and amending Regulation (EC) No. 1907/2007 concerning REACH

Material Safety Data Sheet

Page 6 of 11

MSDS # CP-103

Revision Date: November 2010

Supersedes: August 2010

## Section 9 Physical and Chemical Properties (CONTD.)

<b>APPEARANCE</b>	Dark purple solid with metallic luster
<b>ODOR</b>	Odorless
<b>pH OF THE SUBSTANCE</b>	Not applicable
<b>BOILING POINT/BOILING RANGE</b>	Not applicable
<b>FLASH POINT</b>	Not applicable
<b>FLAMMABILITY (SOLID, GAS)</b>	Not flammable
<b>EXPLOSIVE PROPERTIES</b>	Explosive in contact with sulfuric acid or peroxides, or readily oxidizable substances
<b>OXIDIZING PROPERTIES</b>	Strong oxidizer
<b>VAPOR PRESSURE</b>	Not applicable
<b>RELATIVE DENSITY (AT 20 °C)</b>	2.7
<b>SOLUBILITY</b>	
<b>WATER SOLUBILITY</b>	6% (by weight) at 20 °C and 20% (by weight) at 65 °C
<b>PARTITION COEFFICIENT: n-OCTONAL/WATER</b>	
<b>VISCOSITY</b>	Not applicable
<b>VAPOUR DENSITY</b>	Not applicable
<b>EVAPORATION RATE</b>	Not applicable
<b>MELTING POINT</b>	Starts to decompose with evolution of oxygen (O <sub>2</sub> ) at temperatures above 150°C. Once initiated, the decomposition is exothermic and self sustaining.
<b>MOLECULAR WEIGHT</b>	158.034

## Section 10 Stability and Reactivity

### STABILITY

Under normal conditions, the material is stable.

### CONDITIONS TO AVOID

Contact with incompatible materials or heat (150°C / 302°F) could result in violent exothermic chemical reaction.

### MATERIALS TO AVOID

Acids, peroxides, formaldehyde, anti-freeze, hydraulic fluids and all combustible organic or readily oxidizable inorganic materials including metal powders. With hydrochloric acid, chlorine gas is liberated.

### HAZARDOUS DECOMPOSITION PRODUCTS

When involved in a fire, potassium permanganate may liberate irritating, poisonous and/or corrosive fumes. Oxides of potassium and manganese may be formed.

### CONDITIONS CONTRIBUTING TO HAZARDOUS POLYMERIZATION

Material is not known to polymerize.

## Section 11 Toxicological Information

### EXPOSURE SYMPTOMS DESCRIPTION

#### INHALATION

The product may be absorbed into the body by inhalation. Major effects of exposure: respiratory disorder, cough.

#### INGESTION

Harmful, if swallowed. The estimated lethal human dose is 10 g. Ingestion may cause nausea, vomiting, sore throat, stomach-ache, and eventually lead to a perforation of the intestine. Liver and kidney injuries may occur.



# CAIROX<sup>®</sup> Potassium Permanganate

EC- SAFETY DATA SHEET according to Regulation (EC) № 1272/2008 of the European Parliament and of the Council, of 16 December 2008 and amending Regulation (EC) No. 1907/2007 concerning REACH

Material Safety Data Sheet

Page 7 of 11

MSDS # CP-103

Revision Date: November 2010

Supersedes: August 2010

## Section 11 Toxicological Information (contd.)

### SKIN CONTACT

The product may be absorbed into the body through the skin. Major effects of exposure: severe irritation, damage to the skin, and brown staining of skin.

### EYE CONTACT

Contact with eye is damaging to eye tissues. It may cause severe burns that result in damage to the eye.

### ACUTE TOXICITY

LC 50 inhalation: No data available.

LD 50 dermal: No data available.

LD 50 oral rat: 780 mg/kg male (14 days); 525 mg/kg female (14 days).

Harmful if swallowed. ALD: 10g. Ingestion may cause nausea, vomiting, sore throat, stomach-ache and eventually lead to a perforation of the intestine. Liver and kidney injuries may occur.

### CHRONIC TOXICITY

No known cases of chronic poisoning due to permanganates have been reported. Prolonged exposure, usually over many years, to heavy concentrations of manganese oxides in the form of dust and fumes may lead to chronic manganese poisoning, chiefly involving the central nervous system.

### CARCINOGENICITY

Potassium permanganate has not been classified as a carcinogen by ACGIH, NIOSH, OSHA, NTP, or IARC.

### MEDICAL CONDITIONS GENERALLY AGGRAVATED BY EXPOSURE

Potassium permanganate will cause further irritation of tissue, open wounds, burns or mucous membranes.

## Section 12 Ecological Information

### ECO TOXICITY

Very toxic to aquatic organisms.

### COMPONENT ANALYSIS - AQUATIC TOXICITY

#### Potassium permanganate (7722-64-7)

96Hr LC50	Rainbow trout	1.8 mg/L
96Hr LC50	Bluegill sunfish	2.3 mg/L
96Hr LC50	Milk fish (Chanos Chanos)	>1.4 mg/L
96Hr LC50	Carassius auratus	3.3-3.93 mg/L (static)
96Hr LC50	Cyprinus carpio	2.97-3.11 mg/L
96Hr LC50	Cyprinus carpio	3.16-3.77 mg/L
96Hr LC50	Lepomis macrochirus	2.3 mg/L (flow-through)
96Hr LC50	Lepomis macrochirus	1.8-5.6 mg/L (static)
96Hr LC50	Lepomis macrochirus	2.7 mg/L (static)
96Hr LC50	Oncorhynchus mykiss	1.08-1.38 mg/L
96Hr LC50	Oncorhynchus mykiss	0.77-1.27 mg/L

### MOBILITY

Miscible in water.

### PERSISTENCE AND DEGRADABILITY

Permanganate has a low estimated lifetime in the environment, being readily converted by oxidizable materials to insoluble MnO<sub>2</sub>.





# CAIROX<sup>®</sup> Potassium Permanganate

EC- SAFETY DATA SHEET according to Regulation (EC) № 1272/2008 of the European Parliament and of the Council, of 16 December 2008 and amending Regulation (EC) No. 1907/2007 concerning REACH

Material Safety Data Sheet

Page 8 of 11

MSDS # CP-103

Revision Date: November 2010

Supersedes: August 2010

## Section 12 Ecological Information

### BIOACCUMULATIVE POTENTIAL

In non-reducing and non-acidic environments, MnO<sub>2</sub> is insoluble and has a very low bioaccumulative potential.

### OTHER ADVERSE EFFECTS

Harmful to aquatic organisms.

## Section 13 Disposal Considerations

### WASTE DISPOSAL

Offer surplus and non-recyclable product or solutions to a licensed disposal company. Disposal of all materials shall be in full and strict compliance with all federal, state, and local regulations. This material and its container must be disposed of as hazardous waste. US EPA guidelines for the classification determination are listed in 40 CFR Parts 261.3. When it becomes a waste, potassium permanganate is considered a D001 hazardous (ignitable) waste. For disposal of potassium permanganate solutions, follow procedures in Section 6 and deactivate the permanganate to insoluble manganese dioxide. Dispose of it in a permitted landfill. Contact Carus Corporation for additional recommendations. Packaging materials must be triple rinsed to remove all residues prior to re-cycling or disposal as a non-hazardous waste.

RCRA P-Series: None listed. RCRA U-Series: None listed.

## Section 14 Transport Information

<b>USA (Land, DOT) and Canada (TDG)</b>	<b>ID Number:</b> UN 1490 <b>Proper Shipping Name:</b> Potassium permanganate <b>Hazard Class:</b> Oxidizer <b>Packing Group:</b> II <b>Division:</b> 5.1 <b>Product packaging containing ≥100 lbs</b> <b>ID Number:</b> UN 1490 <b>Proper Shipping Name:</b> Potassium permanganate, RQ <b>Hazard Class:</b> Oxidizer <b>Packing Group:</b> II <b>Division:</b> 5.1 <b>Additional Info.:</b> If this product is spilled or leaked into the environment, the CERCLA (40 CFR 302.4) reportable quantity is 100 lbs, and requires National Response Center notification within United States of America.
<b>European Labeling in accordance Road/Rail Transport (ADR/RID)</b>	<b>ID Number:</b> UN 1490 <b>ADR/RID Class:</b> 5.1 <b>Description of Goods:</b> Potassium permanganate <b>Packing Group:</b> II <b>Hazard Identification No.:</b> 50
<b>European Labeling in accordance with EC directive (Water, IMDG)</b>	<b>ID Number:</b> UN 1490 <b>Proper Shipping Name:</b> Potassium permanganate <b>Hazard Class:</b> Oxidizer <b>Packing Group:</b> II <b>Division:</b> 5.1 <b>Marine Pollutant:</b> No
<b>European Labeling in accordance with EC directive (IACO, IATA)</b>	<b>ID Number:</b> UN 1490 <b>Proper Shipping Name:</b> Potassium permanganate <b>Hazard Class:</b> Oxidizer <b>Packing Group:</b> II <b>Division:</b> 5.1



# CAIROX<sup>®</sup> Potassium Permanganate

EC- SAFETY DATA SHEET according to Regulation (EC) № 1272/2008 of the European Parliament and of the Council, of 16 December 2008 and amending Regulation (EC) No. 1907/2007 concerning REACH

Material Safety Data Sheet

Page 9 of 11

MSDS # CP-103

Revision Date: November 2010

Supersedes: August 2010

## Section 15 Regulatory Information

### EUROPEAN AND INTERNATIONAL REGULATIONS

#### GERMANY WATER CLASSIFICATION

Potassium permanganate (7722-64-7)

Number 1936, hazard class 3 - severe hazard to waters

#### CLP CLASSIFICATION

This product is hazardous according to the Regulation (EC) No. 1272/2008 on Classification, Labeling and Packaging of Substances and Mixtures (CLP).

Oxidizing solid, Category 2

Acute toxicity, Category 4

Hazardous to the Aquatic Environment - Hazard, Category 1

Hazardous to the Aquatic Environment - Hazard, Category 1

#### CLP HAZARD SYMBOLS



#### CLP HAZARD STATEMENTS

H272	May intensify fire, oxidizer
H302	Harmful, if swallowed
H410	Very toxic to aquatic life with long lasting effects
P210	Keep away from heat/sparks/open flames/hot surfaces. – No smoking
P220	Keep/Store away from clothing/combustible materials.
P260	Do not breathe dust
P280	Wear protective gloves/protective clothing/eye protection/face protection
P370 + P378	In case of fire: Use water for extinction
P501	Dispose of contents/container to appropriate places
P273	Avoid release to the environment.

#### COMPONENT ANALYSIS – INVENTORY

COMPONENT	CAS#	US	CA	EU	AU	PH	JP	KR	CN	NZ
Potassium permanganate	7722-64-7	TSCA	DSL	EIN	Yes	Yes	Yes	Yes	Yes	Yes

This product has also been classified in accordance with the hazard criteria of the Controlled Products Regulation (CPR, Canada) and the MSDS contains all of the information required by the CPR.



# CAIROX<sup>®</sup> Potassium Permanganate

EC- SAFETY DATA SHEET according to Regulation (EC) № 1272/2008 of the European Parliament and of the Council, of 16 December 2008 and amending Regulation (EC) No. 1907/2007 concerning REACH

Material Safety Data Sheet

Page 10 of 11

MSDS # CP-103

Revision Date: November 2010

Supersedes: August 2010

## Section 15 Regulatory Information (contd.)

### US FEDERAL REGULATIONS:

#### FEDERAL, STATE & INTERNATIONAL REGULATIONS – PART 1

<u>Ingredient</u>	<u>CAS. NO.</u>	<u>SARA 302</u>		<u>SARA 313</u>	
		<u>RQ</u>	<u>TPQ</u>	<u>List</u>	<u>Chemical Category</u>
Potassium permanganate	7722-64-7	No	No	Yes	Yes (Manganese compounds)

#### FEDERAL, STATE & INTERNATIONAL REGULATIONS – PART 2

<u>Ingredient</u>	<u>CAS. NO.</u>	<u>CERCLA</u>	<u>RCRA</u>	<u>TSCA 8(d)</u>
Potassium permanganate	7722-64-7	Yes (RQ = 100 lbs)	D001	No

<u>Ingredient</u>	<u>CAS. NO.</u>	<u>CWC</u>	<u>TSCA 12(b)</u>	<u>CDTA</u>	<u>SARA 311/312</u>
Potassium permanganate	7722-64-7	No	No		4545 Kg

<u>Ingredient</u>	<u>CAS. NO.</u>	<u>Acute</u>	<u>Chronic</u>	<u>Fire</u>	<u>Pressure</u>	<u>Reactivity</u>	<u>Pure/Liquid</u>
Potassium permanganate	7722-64-7	Yes	Yes	Yes	No	No	Pure

<u>Ingredient</u>	<u>CAS. NO.</u>	<u>Australian Hazchem</u>	<u>WHMIS</u>	<u>IDL</u>
Potassium permanganate	7722-64-7	IYE	C, D2B	Yes

## Section 16 Other Information

ADR/RID	Agreement on Dangerous Goods by Road /Regulations Concerning the International Transport of Dangerous Goods by Rail
C	Ceiling Exposure Limit
CAS	Chemical Abstract Service
CFR	Code of Federal Regulations
CERCLA	Comprehensive Environmental Response, Compensation, and Liability Act
CHEMTREC	Chemical Transportation Emergency Center
EINECS	Inventory of Existing Chemical Substances (European)
DOT	Department of Transportation
DSL/NDSL	The Domestic Substances and the Non-Domestic Substances List (Canada)
HIMS	Hazardous Materials Information System
IARC	International Agency for Research on Cancer
IATA	International Air Transport Association
ICAO	International Civil Aviation Center
IDL	Ingredient Disclosure List
IMDG	International Maritime Dangerous Goods
OSHA	Occupational Safety and Health Administration
NIOSH	National Institute for Occupational Safety and Health
NTP	National Toxicology Program
MSHA	Mine Safety and Health Administration
PEL	Permissible Exposure Limit
SARA	Superfund Amendments and Reauthorization Act
TDG	Transport Dangerous Goods (Canada)
TSCA	Toxic substances control Act
TLV-TWA	Threshold Limit Value-Time Weighted Average
UN	United Nations
WHMIS	Workplace Hazardous Materials Information System



# CAIROX<sup>®</sup> Potassium Permanganate

EC- SAFETY DATA SHEET according to Regulation (EC) № 1272/2008 of the European Parliament and of the Council, of 16 December 2008 and amending Regulation (EC) No. 1907/2007 concerning REACH

Material Safety Data Sheet

Page 11 of 11

MSDS # CP-103

Revision Date: November 2010

Supersedes: August 2010

## Section 16 Other Information (contd.)

The information contained herein is accurate to the best of our knowledge. However, data, safety standards and government regulations are subject to change and, therefore, holders and users should satisfy themselves that they are aware of all current data and regulations relevant to their particular use of product. CARUS CORPORATION DISCLAIMS ALL LIABILITY FOR RELIANCE ON THE COMPLETENESS OR ACCURACY OR THE INFORMATION INCLUDED HEREIN. CARUS CORPORATION MAKES NO WARRANTY, EITHER EXPRESS OR IMPLIED, INCLUDING, BUT NOT LIMITED TO, ANY WARRANTIES OF MERCHANTABILITY OR FITNESS FOR PARTICULAR USE OR PURPOSE OF THE PRODUCT DESCRIBED HEREIN. All conditions relating to storage, handling, and use of the product are beyond the control of Carus Corporation, and shall be the sole responsibility of the holder or user of the product.

This safety data sheet was reviewed according to Annex II of the regulation of the European Parliament and European Council (EC) No. 1907/2006-REACH and 1272/2008.

CARUS CORPORATION, 315 5<sup>TH</sup> STREET, PERU, ILLINOIS 61354, USA  
CARUS EUROPE IS A DIVISION OF CARUS CORPORATION

Chithambarathanu Pillai (S.O.F.)  
November 2010



CARUS<sup>®</sup> (Carus and design) is a registered service mark of Carus Corporation. CAIROX<sup>®</sup> is a registered trademark of Carus Corporation. Copyright 1998. Responsible Care<sup>®</sup> is a registered service mark of the American Chemistry Council